



2 Contents

	Page
1 COVER PAGE	1
2 CONTENTS	2
3 REVISION HISTORY	3
4 GENERAL INFORMATION	4
4.1 GENERAL DESCRIPTION OF E.U.T.	4
4.2 DETAILS OF E.U.T.	4
4.3 SUBCONTRACTED	4
4.4 ABNORMALITIES FROM STANDARD CONDITIONS	4
5 TEST SUMMARY	5
6 EQUIPMENT USED DURING TEST	6
6.1 EQUIPMENTS LIST	6
6.2 DESCRIPTION OF SUPPORT UNITS	9
6.3 MEASUREMENT UNCERTAINTY	9
6.4 TEST EQUIPMENT CALIBRATION	9
6.5 TEST MODES	9
7 EMC REQUIREMENTS FOR EMISSIONS	10
7.1 RADIATED EMISSIONS	10
8 EMC REQUIREMENT FOR IMMUNITY	16
8.1 PERFORMANCE CRITERIA DESCRIPTION	16
8.2 ELECTROSTATIC DISCHARGE(ESD)	19
8.3 RADIATED IMMUNITY(R/S)	22
9 PHOTOGRAPHS – TEST SETUP	24
9.1 PHOTOGRAPH - RADIATED EMISSIONS TEST SETUP	24
9.2 PHOTOGRAPH - RADIATED IMMUNITY TEST SETUP	25
9.3 PHOTOGRAPH - ESD TEST SETUP	25
10 PHOTOGRAPHS OF EUT	26
10.1 EUT– APPEARANCEVIEW	26



3 Revision History

Test report No.	Date of Receipt sample	Date of Test	Date of Issue	Purpose	Comment	Approved
WTF21D01009792 W003	2021-02-01	2021-02-01 to 2021-02-08	2021-02-25	Original	-	Valid

WALTEK



4 General Information

4.1 General Description of E.U.T.

Product: Health bracelet
Model(s): MO6195
Model Description: N/A
Bluetooth Version: V4.0
Hardware Version: PCB-M3G0-V1.0
Software Version: 92040020

4.2 Details of E.U.T.

Ratings: Input: 5V $\overline{\text{---}}$
Battery: 3.7 $\overline{\text{---}}$, 90mAh

4.3 Subcontracted

Whether parts of tests for the product have been subcontracted to other labs:

Yes No

If Yes, list the related test items and lab information:

Test Lab: /

Lab address: /

Test items: /

4.4 Abnormalities from Standard Conditions

None.



5 Test Summary

EMC PART		
Test Items	Test Requirement	Result
Conducted Emissions	EN 301 489-17	N/A
Radiated Emissions	EN 301 489-17	PASS
Harmonic Current Emissions	EN 301 489-17	N/A
Voltage Fluctuations and Flicker	EN 301 489-17	N/A
Electrostatic Discharge(ESD)	EN 301 489-17	PASS
Radiated Immunity (R/S)	EN 301 489-17	PASS
Electrical Fast Transients (EFT)	EN 301 489-17	N/A
Surge Immunity	EN 301 489-17	N/A
Conducted Immunity (C/S)	EN 301 489-17	N/A
Voltage Dips and Interruptions	EN 301 489-17	N/A

Remark:
PASS: Test item meets the requirement
N/A: Not Applicable

WALTEK



6 Equipment Used during Test

6.1 Equipments List

Conducted Emissions						
Item	Equipment	Manufacturer	Model No.	Serial No.	Last Calibration Date	Calibration Due Date
1	EMI Test Receiver	R&S	ESCI	101155	2020-07-30	2021-07-29
2	LISN	SCHWARZBECK	NSLK 8128	8128-259	2020-07-30	2021-07-29
3	Limiter	CYBERTEK	EM5010	261115-001-0024	2020-07-30	2021-07-29
4	Cable	Laplace	RF300	-	2020-07-30	2021-07-29
5	Universal Radio Communication Tester	R&S	CMU 200	121315	2020-04-20	2021-04-19
6	Universal Radio Communication Tester	R&S	CMW500	127818	2020-04-20	2021-04-19
3m Semi-anechoic Chamber for Radiation Emissions						
Item	Equipment	Manufacturer	Model No.	Serial No.	Last Calibration Date	Calibration Due Date
1	Spectrum Analyzer	R&S	FSP	100091	2020-04-20	2021-04-19
2	Amplifier	Agilent	8447D	2944A10178	2020-04-20	2021-04-19
3	Active Loop Antenna	Beijing Dazhi	ZN30900A	0703	2020-04-20	2021-04-19
4	Trilog Broadband Antenna	SCHWARZBECK	VULB9163	336	2020-08-11	2021-08-10
5	Coaxial Cable (below 1GHz)	Top	TYPE16(13M)	-	2020-04-20	2021-04-19
6	Broad-band Horn Antenna	SCHWARZBECK	BBHA 9120 D	667	2020-04-19	2021-04-18
7	Broadband Preamplifier	COMPLIANCE DIRECTION	PAP-1G18	2004	2020-04-20	2021-04-19
8	Coaxial Cable (above 1GHz)	Top	1GHz-25GHz	EW02014-7	2020-04-20	2021-04-19
9	Universal Radio Communication Tester	R&S	CMU 200	121315	2020-04-20	2021-04-19
10	Universal Radio Communication Tester	R&S	CMW 500	127818	2020-04-20	2021-04-19
Harmonic/ Flicker						
Item	Equipment	Manufacturer	Model No.	Serial No.	Last Calibration Date	Calibration Due Date
1	Digital Power Analyzer	SCHAFFNER	CCN 1000-1	72625	2020-04-20	2021-04-19
2	Power Source	SCHAFFNER	NSG 1007	58477	2020-04-20	2021-04-19
3	Universal Radio	R&S	CMU 200	112461	2020-04-20	2021-04-19



	Communication Tester					
4	Universal Radio Communication Tester	R&S	CMW500	127818	2020-04-20	2021-04-19
Electrostatic Discharge						
Item	Equipment	Manufacturer	Model No.	Serial No.	Last Calibration Date	Calibration Due Date
1	Electrostatic Discharge Simulator	SCHLODER	SESD 216	606144	2020-04-24	2021-04-23
2	Universal Radio Communication Tester	R&S	CMU 200	112461	2020-04-20	2021-04-19
Conducted Immunity						
Item	Equipment	Manufacturer	Model No.	Serial No.	Last Calibration Date	Calibration Due Date
1	RF Generator	TESEQ	NSG4070	25781	2020-07-30	2021-07-29
2	CDN M-Type	TESEQ	CDN M016	25112	2020-07-30	2021-07-29
3	EM-Clamp	TESEQ	KEMZ 801	25453	2020-07-30	2021-07-29
4	Attenuator 6dB	TESEQ	ATN6050	25365	2020-07-30	2021-07-29
5	Universal Radio Communication Tester	R&S	CMU 200	112461	2020-04-20	2021-04-19
6	Audio Analyzer	R&S	UPV	102011	2020-07-30	2021-07-29
7	Universal Radio Communication Tester	R&S	CMW500	127818	2020-04-20	2021-04-19
Surge, EFT, Voltage dips and Interruption						
Item	Equipment	Manufacturer	Model No.	Serial No.	Last Calibration Date	Calibration Due Date
1	All Modules Generator	SCHAFFNER	6150	34579	2020-07-30	2021-07-29
2	EMS Modules Generator	EMC PARTNER TRANSIENT	2000	494	2020-07-30	2021-07-29
3	Capacitive Coupling Clamp	SCHAFFNER	CDN 8014	25311	2020-07-30	2021-07-29
4	Signal and Data Line Coupling Network	SCHAFFNER	CDN 117	25627	2020-07-30	2021-07-29
5	Universal Radio Communication Tester	R&S	CMU 200	112461	2020-04-20	2021-04-19
6	Universal Radio Communication Tester	R&S	CMW500	127818	2020-04-20	2021-04-19
Radio-frequency electromagnetic fields						
Item	Equipment	Manufacturer	Model No.	Serial No.	Last Calibration Date	Calibration Due Date
1	Signal Generator	R&S	SMB100A	105942	2020-07-30	2021-07-29
2	Power Amplifier	BONN Elektronik	BLWA0830-160/100/40D	128740	2020-07-30	2021-07-29



3	Gestockte Breitband (S tacked) Log.-per.Antenna	SCHWARZBECK	STLP9128D	043	2020-07-30	2021-07-29
4	Power Meter	R&S	NRP2	102031	2020-04-20	2021-04-19
5	Universal Radio Communication Tester	R&S	CMU 200	112461	2020-04-20	2021-04-19
6	Audio Analyzer	R&S	UPV	102011	2020-07-30	2021-07-29
7	Universal Radio Communication Tester	R&S	CMW500	127818	2020-04-20	2021-04-19
3m Semi-anechoic Chamber for Radiation(TDK)						
Item	Equipment	Manufacturer	Model No.	Serial No	Last Calibration Date	Calibration Due Date
1	Test Receiver	R&S	ESCI	101296	2020-04-20	2021-04-19
2	Trilog Broadband Antenna	SCHWARZBECK	VULB9160	9160-3325	2020-04-25	2021-04-24
3	Amplifier	ANRITSU	MH648A	M43381	2020-04-20	2021-04-19
4	Cable	HUBER+SUHNER	CBL2	525178	2020-04-20	2021-04-19
5	Universal Radio Communication Tester	R&S	CMU 200	112461	2020-04-20	2021-04-19
6	Universal Radio Communication Tester	R&S	CMW500	127818	2020-04-20	2021-04-19



6.2 Description of Support Units

Equipment	Manufacturer	Model No.	Series No.
/	/	/	/

6.3 Measurement Uncertainty

Parameter	Uncertainty
Conduction disturbance(150kHz~30MHz)	±3.64dB
Radiated Emission(30MHz~1GHz)	±5.08dB
Radiated Emission(1GHz~6GHz)	±4.99dB

6.4 Test Equipment Calibration

All the test equipments used are valid and calibrated by CEPREI Certification Body that address is No.110 Dongguan Zhuang RD. Guangzhou, P.R.China.

6.5 Test Modes

Radiated Emissions	
TM1*	Bluetooth link
Electrostatic Discharge(ESD)	
TM1*	Bluetooth link
Radiated Immunity(R/S)	
TM1*	Bluetooth link
Note:All test mode were tested and passed	



7 EMC Requirements for Emissions

7.1 Radiated Emissions

Test Method	: EN 301 489-1, EN 55032
Frequency Range	: 30MHz to 1GHz, 1GHz to 6GHz
Class/Severity	: Class B/ Table A.4 of EN 55032 (30MHz to 1GHz) Class B/ A.5 of EN 55032 (1GHz to 6GHz)
Detector	: Peak for pre-scan (120kHz Resolution Bandwidth Below 1GHz; 1MHz Resolution Bandwidth Above 1GHz)

7.1.1 EUT Operation:

Operating Environment :

Temperature	: 22.5°C
Humidity	: 52.1 % RH
Atmospheric Pressure	: 101.2kPa

EUT Operation :

Refer to section 7.5.

7.1.2 Test Setup

The radiated emission tests were performed using the setup accordance with the EN 55032.

Frequency Range: Below 1 GHz

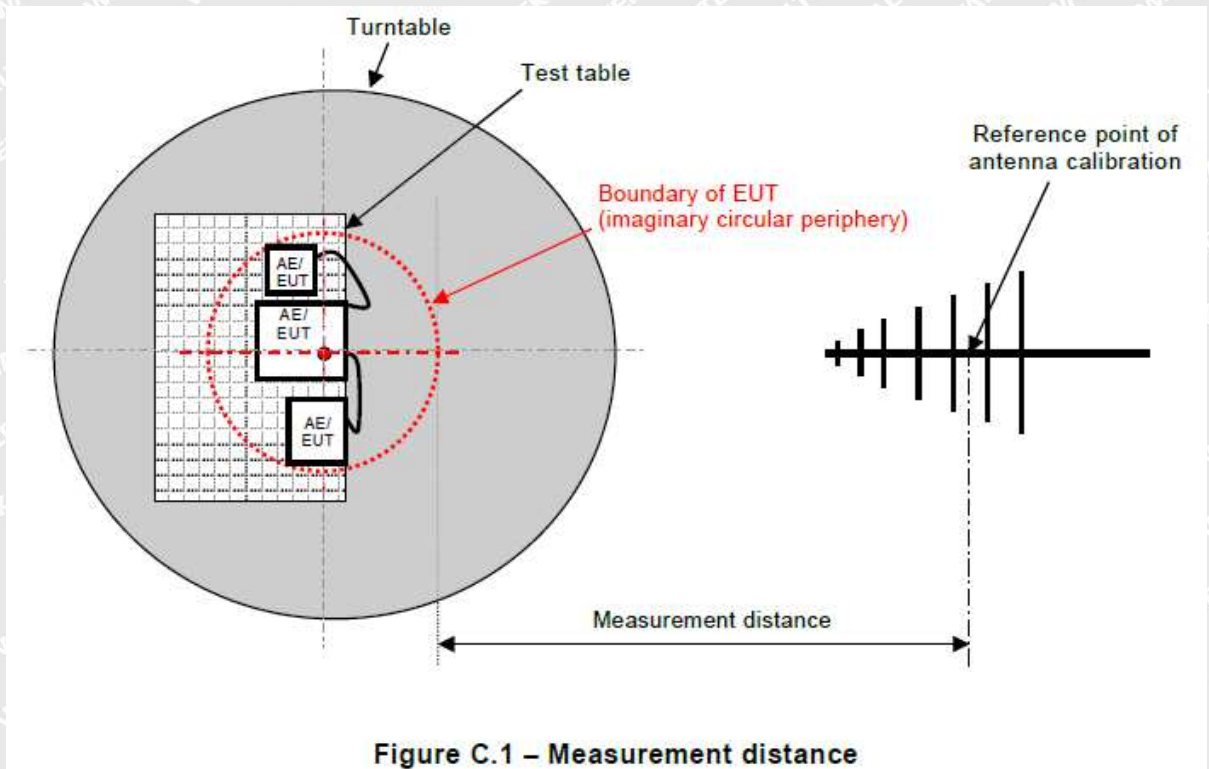

Figure C.1 – Measurement distance



Frequency Range: Above 1 GHz

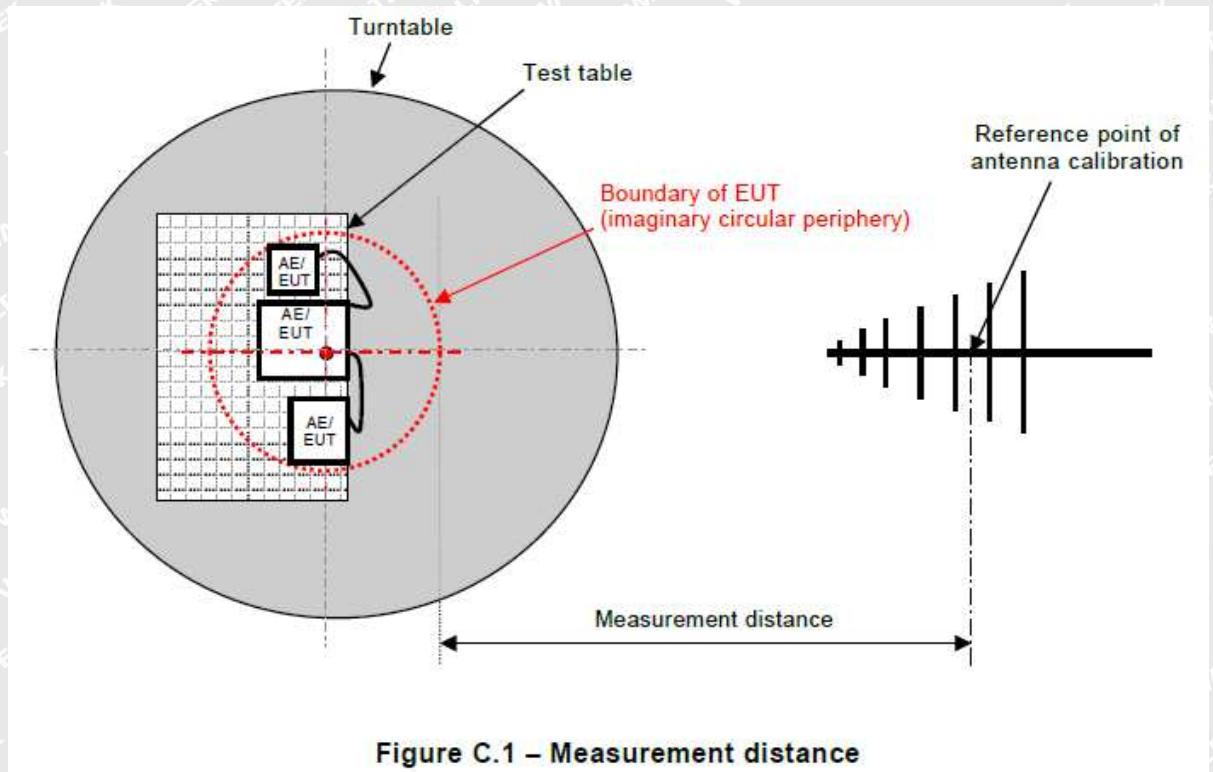

Figure C.1 – Measurement distance

7.1.3 Corrected Amplitude & Margin Calculation

The Corrected Amplitude is calculated by adding the Antenna Factor and Cable Factor, and subtracting the Amplifier Gain from the Amplitude reading. The basic equation is as follows:

$$\text{Corr. Ampl.} = \text{Indicated Reading} + \text{Antenna Factor} + \text{Cable Factor} - \text{Amplifier Gain}$$

The “Margin” column of the following data tables indicates the degree of compliance with the applicable limit. For example, a margin of -7dB means the emission is 7dB below the maximum limit for Class B. The equation for margin calculation is as follows:

$$\text{Margin} = \text{Corr. Ampl.} - \text{Class B Limit}$$



7.1.4 Test Result

Frequency Range: 30MHz ~ 1000MHz

Antenna Polarization: Horizontal

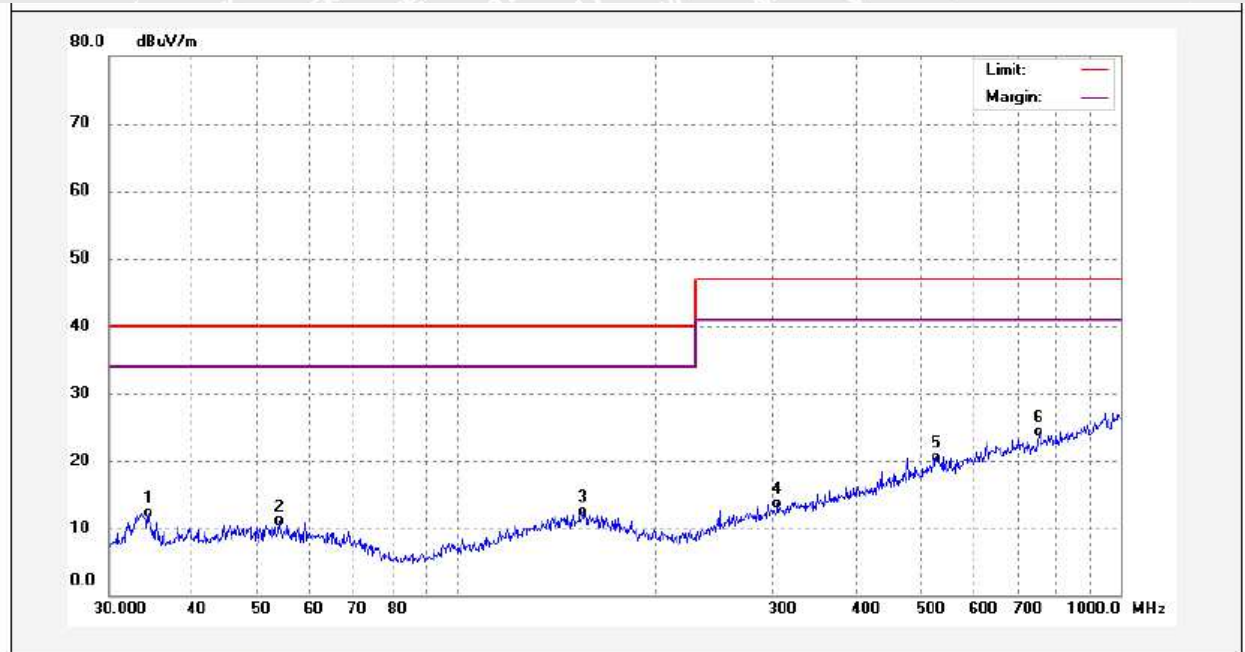

No.	Freq. (MHz)	Reading (dBuV/m)	Factor (dB)	Result (dBuV/m)	Limit (dBuV/m)	Margin (dB)	Detector	Remark
1	34.3964	30.34	-17.97	12.37	40.00	-27.63	QP	
2	54.0711	28.14	-17.01	11.13	40.00	-28.87	QP	
3	154.8204	27.86	-15.33	12.53	40.00	-27.47	QP	
4	304.6099	28.26	-14.62	13.64	47.00	-33.36	QP	
5	526.3967	28.90	-8.42	20.48	47.00	-26.52	QP	
6	752.7432	29.56	-5.28	24.28	47.00	-22.72	QP	



Antenna Polarization: Vertical

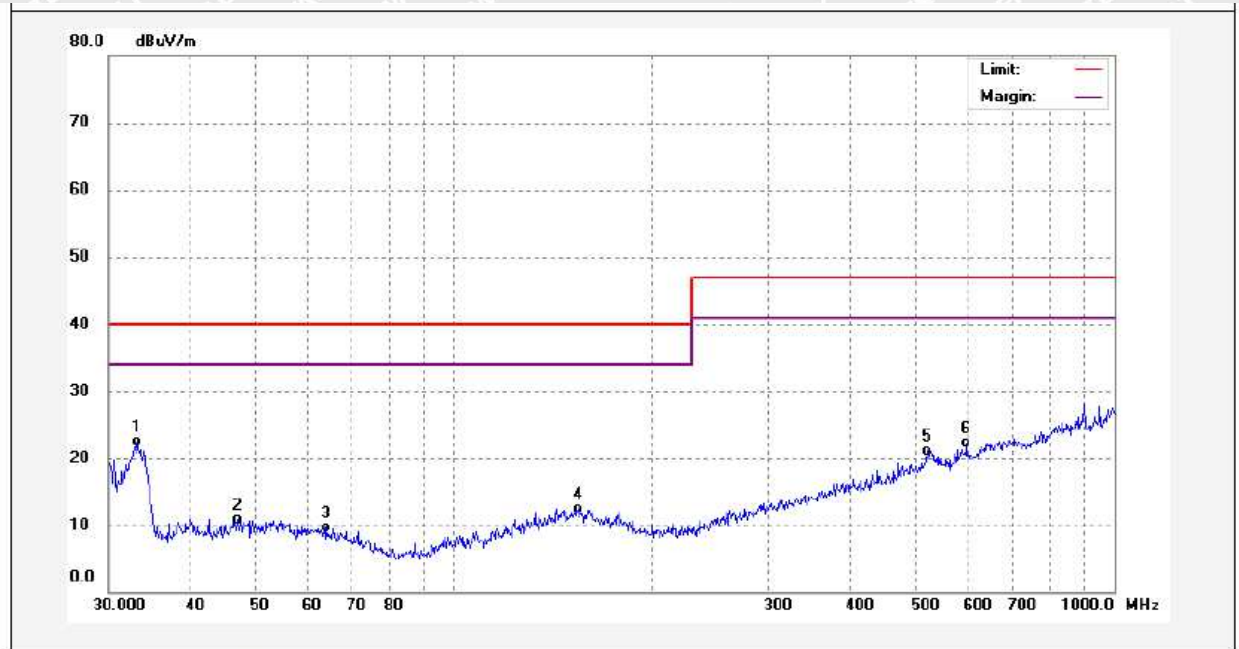

No.	Freq. (MHz)	Reading (dBuV/m)	Factor (dB)	Result (dBuV/m)	Limit (dBuV/m)	Margin (dB)	Detector	Remark
1	33.2112	40.57	-18.03	22.54	40.00	-17.46	QP	
2	47.1598	28.03	-17.12	10.91	40.00	-29.09	QP	
3	64.2074	27.51	-17.85	9.66	40.00	-30.34	QP	
4	154.2785	27.78	-15.32	12.46	40.00	-27.54	QP	
5	520.8882	29.86	-8.68	21.18	47.00	-25.82	QP	
6	597.2234	30.40	-8.08	22.32	47.00	-24.68	QP	



Frequency Range: 1000MHz ~ 6000MHz

Antenna Polarization: Horizontal

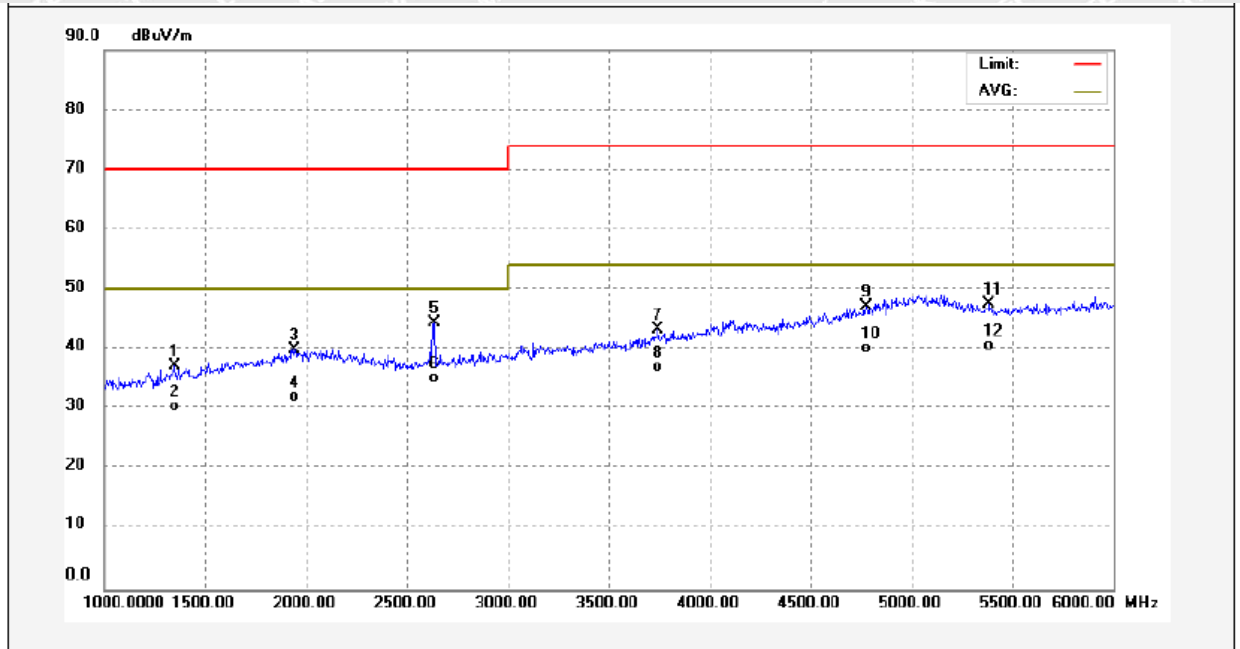

No.	Freq. (MHz)	Reading (dBuV/m)	Factor (dB)	Result (dBuV/m)	Limit (dBuV/m)	Margin (dB)	Detector	Remark
1	1350.000	49.59	-12.39	37.20	70.00	-32.80	peak	
2	1350.000	42.84	-12.39	30.45	50.00	-19.55	AVG	
3	1940.000	48.91	-8.94	39.97	70.00	-30.03	peak	
4	1940.000	41.09	-8.94	32.15	50.00	-17.85	AVG	
5	2635.000	52.19	-7.76	44.43	70.00	-25.57	peak	
6	2635.000	42.94	-7.76	35.18	50.00	-14.82	AVG	
7	3745.000	50.09	-6.77	43.32	74.00	-30.68	peak	
8	3745.000	43.68	-6.77	36.91	54.00	-17.09	AVG	
9	4775.000	51.87	-4.74	47.13	74.00	-26.87	peak	
10	4775.000	44.80	-4.74	40.06	54.00	-13.94	AVG	
11	5385.000	50.82	-3.20	47.62	74.00	-26.38	peak	
12	5385.000	43.81	-3.20	40.61	54.00	-13.39	AVG	



Antenna Polarization: Vertical

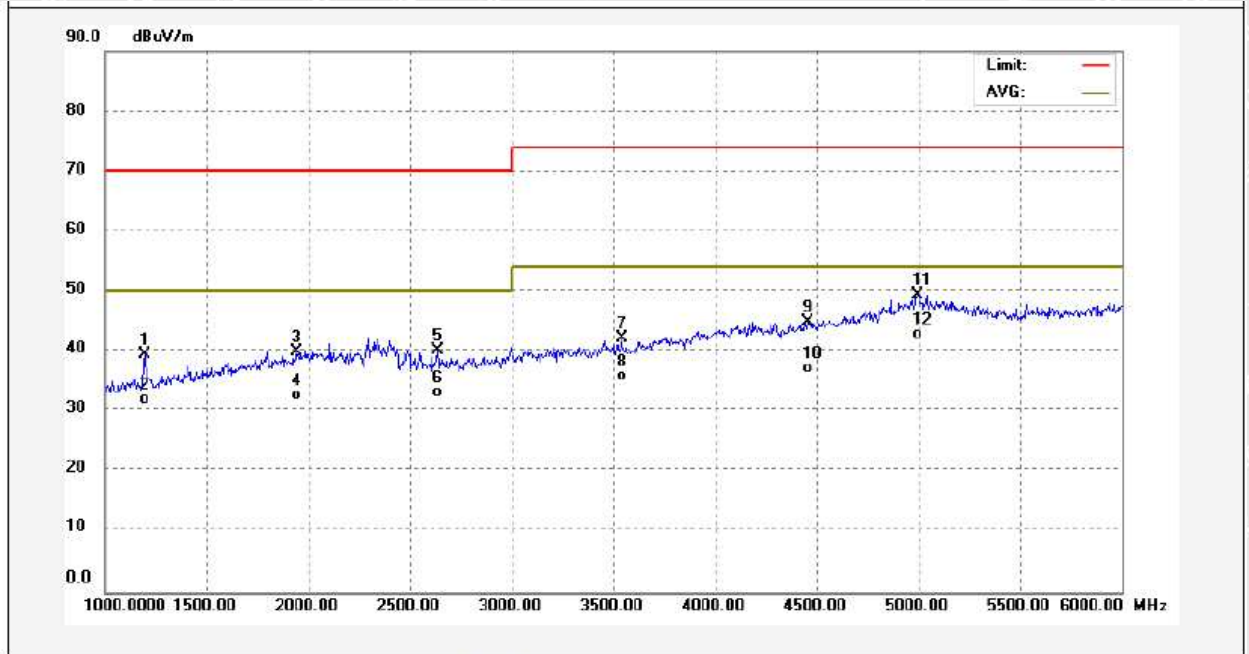

No.	Freq. (MHz)	Reading (dBuV/m)	Factor (dB)	Result (dBuV/m)	Limit (dBuV/m)	Margin (dB)	Detector	Remark
1	1195.000	54.79	-15.39	39.40	70.00	-30.60	peak	
2	1195.000	47.55	-15.39	32.16	50.00	-17.84	AVG	
3	1940.000	50.74	-10.78	39.96	70.00	-30.04	peak	
4	1940.000	43.59	-10.78	32.81	50.00	-17.19	AVG	
5	2635.000	51.98	-11.79	40.19	70.00	-29.81	peak	
6	2635.000	44.97	-11.79	33.18	50.00	-16.82	AVG	
7	3540.000	51.28	-9.04	42.24	74.00	-31.76	peak	
8	3540.000	44.98	-9.04	35.94	54.00	-18.06	AVG	
9	4455.000	50.29	-5.42	44.87	74.00	-29.13	peak	
10	4455.000	42.60	-5.42	37.18	54.00	-16.82	AVG	
11	4995.000	50.80	-1.40	49.40	74.00	-24.60	peak	
12	4995.000	44.24	-1.40	42.84	54.00	-11.16	AVG	



8 EMC Requirement for Immunity

8.1 Performance Criteria Description

ETSI EN 301 489-1 V2.2.3 Clause 6 requirements:

The performance criteria are used to take a decision on whether a radio equipment passes or fails immunity tests.

For the purpose of the present document four categories of performance criteria apply:

- performance criteria for continuous phenomena applied to transmitters(CT);
- performance criteria for transient phenomena applied to transmitters(TT);
- performance criteria for continuous phenomena applied to receivers(CR);
- performance criteria for transient phenomena applied to receivers(TR).

Normally, the performance criteria depend on the type of radio equipment. Thus, the present document only contains general performance criteria commonly used for the assessment of radio equipment. More specific and product-related performance criteria for a dedicated type of radio equipment may be found in the part of EN 301 489 series [i.13] dealing with the particular type of radio equipment.

Performance Criteria	Description
CT,CR	<p>If no further details are given in the relevant part of EN 301 489 series [i.13] dealing with the particular type of radio equipment, the following general performance criteria for continuous phenomena shall apply.</p> <p>During and after the test, the apparatus shall continue to operate as intended. No degradation of performance or loss of function is allowed below a permissible performance level specified by the manufacturer when the apparatus is used as intended. In some cases this permissible performance level may be replaced by a permissible loss of performance.</p> <p>During the test the EUT shall not unintentionally transmit or change its actual operating state and stored data.</p> <p>If the minimum performance level or the permissible performance loss is not specified by the manufacturer, then either of these may be deduced from the product description and documentation and what the user may reasonably expect from the apparatus if used as intended.</p>
TT,TR	<p>If no further details are given in the relevant part of EN 301 489 series [i.13] dealing with the particular type of radio equipment, the following general performance criteria for transient phenomena shall apply. After the test, the apparatus shall continue to operate as intended. No degradation of performance or loss of function is allowed below a permissible performance level specified by the manufacturer, when the apparatus is used as intended. In some cases this permissible performance level may be replaced by a permissible loss of performance.</p> <p>During the EMC exposure to an electromagnetic phenomenon, a degradation of performance is, however, allowed. No change of the actual mode of operation (e.g. unintended transmission) or stored data is allowed.</p> <p>If the minimum performance level or the permissible performance loss is not specified by the manufacturer, then either of these may be deduced from the product description and documentation and what the user may reasonably expect from the apparatus if used as intended.</p>

ETSI EN 301 489-17 V3.1.1 Clause 6 requirements:

The performance criteria are:

- performance criteria A for immunity tests with phenomena of a continuous nature;
- performance criteria B for immunity tests with phenomena of a transient nature;
- performance criteria C for immunity tests with power interruptions exceeding a certain time.

The equipment shall meet the minimum performance criteria as specified in the following clauses.

Criteria	During test	After test
A	Shall operate as intended. May show degradation of performance (see note 1). Shall be no loss of function. Shall be no unintentional transmissions.	Shall operate as intended. Shall be no degradation of performance (see note 2). Shall be no loss of function. Shall be no loss of stored data or user programmable functions.
B	May show loss of function (one or more). May show degradation of performance (see note 1). No unintentional transmissions.	Functions shall be self-recoverable. Shall operate as intended after recovering. Shall be no degradation of performance (see note 2). Shall be no loss of stored data or user programmable functions.
C	May be loss of function (one or more).	Functions shall be recoverable by the operator. Shall operate as intended after recovering. Shall be no degradation of performance (see note 2).

NOTE 1: Degradation of performance during the test is understood as a degradation to a level not below a minimum performance level specified by the manufacturer for the use of the apparatus as intended. In some cases the specified minimum performance level may be replaced by a permissible degradation of performance.

If the minimum performance level or the permissible performance degradation is not specified by the manufacturer then either of these may be derived from the product description and documentation (including leaflets and advertising) and what the user may reasonably expect from the apparatus if used as intended.

NOTE 2: No degradation of performance after the test is understood as no degradation below a minimum performance level specified by the manufacturer for the use of the apparatus as intended. In some cases the specified minimum performance level may be replaced by a permissible degradation of performance. After the test no change of actual operating data or user retrievable data is allowed. If the minimum performance level or the permissible performance degradation is not specified by the manufacturer then either of these may be derived from the product description and documentation (including leaflets and advertising) and what the user may reasonably expect from the apparatus if used as intended.

Performance Criteria	Description
CT	The performance criteria A shall apply. Tests shall be repeated with the EUT in standby mode (if applicable) to ensure that unintentional transmission does not occur. In systems using acknowledgement signals, it is recognized that an ACKnowledgement (ACK) or Not ACKnowledgement (NACK) transmission may occur, and steps should be taken to ensure that any transmission resulting from the application of the test is correctly interpreted.



TT	<p>The performance criteria B shall apply, except for voltage dips of 100 ms and voltage interruptions of 5 000 ms duration, for which performance criteria C shall apply.</p> <p>Tests shall be repeated with the EUT in standby mode (if applicable) to ensure that unintentional transmission does not occur. In systems using acknowledgement signals, it is recognized that an acknowledgement (ACK) or not-acknowledgement (NACK) transmission may occur, and steps should be taken to ensure that any transmission resulting from the application of the test is correctly interpreted.</p>
CR	<p>The performance criteria A shall apply.</p> <p>Where the EUT is a transceiver, under no circumstances, shall the transmitter operate unintentionally during the test. In systems using acknowledgement signals, it is recognized that an ACK or NACK transmission may occur, and steps should be taken to ensure that any transmission resulting from the application of the test is correctly interpreted.</p>
TR	<p>The performance criteria B shall apply, except for voltage dips of 100 ms and voltage interruptions of 5 000 ms duration for which performance criteria C shall apply.</p> <p>Where the EUT is a transceiver, under no circumstances, shall the transmitter operate unintentionally during the test. In systems using acknowledgement signals, it is recognized that an ACK or NACK transmission may occur, and steps should be taken to ensure that any transmission resulting from the application of the test is correctly interpreted.</p>

Emission

1. General

EN 301 489-1 [1], table 2 contains the applicability of EMC emission measurements to the relevant ports of radio equipment.

2. Special conditions

No special conditions shall apply to radio equipment in the scope of the present document.

Immunity

1. General

EN 301 489-1 [1], table 2, contains the applicability of EMC immunity measurements to the relevant ports of radio equipment.

2. Special conditions

No special conditions are relevant for products covered in the present document



8.2 Electrostatic Discharge(ESD)

Test Method	: EN 301 489-1, EN 61000-4-2
Discharge Impedance	: 330 Ω / 150 pF
Discharge Voltage	: Air Discharge: +/-2,4,8 KV Contact Discharge: +/-2,4 KV HCP & VCP: +/-2,4 KV
Polarity	: Positive & Negative
Discharge Repeat Times	: At Least 20 times at each test point
Discharge Mode	: Single Discharge
Discharge Period	: 1 second minimum

8.2.1 E.U.T. Operation

Operating Environment:

Temperature	: 21.5°C
Humidity	: 52.0 % RH
Barometric Pressure	: 101.3kPa

EUT Operation:

Refer to section 7.5.

8.2.2 Block Diagram of Setup

The ESD test was performed in accordance with the EN 61000-4-2.

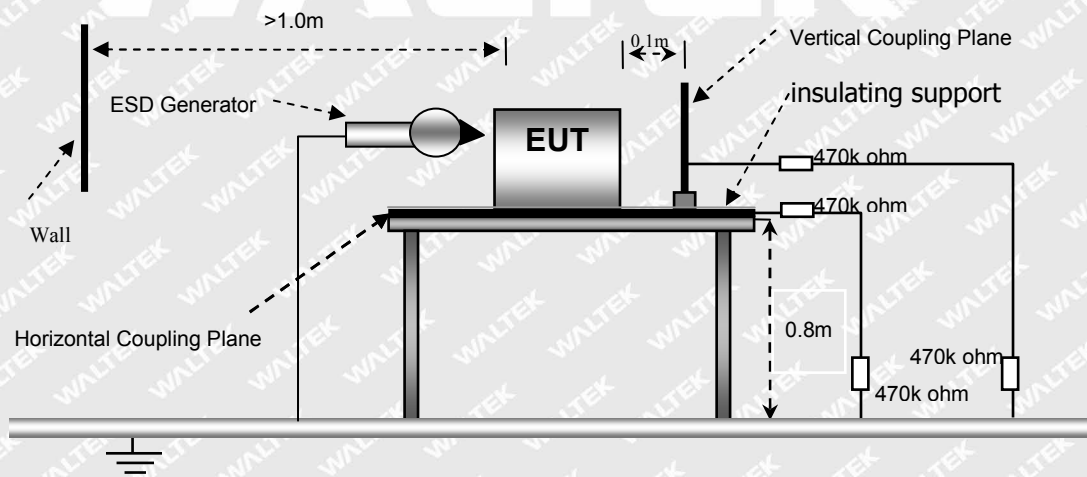



8.2.3 Test Results

Indirect Application			Performance Criteria	
Discharge Level (kV)	Polarity (+/-)	Test Point	Horizontal Coupling	Vertical Coupling
2,4	+/-	1	TT/TR	TT/TR

Remark:
Test points : 1. All sides(Front/Top/ Back/ Left/Right Sides).

Direct Application			Performance Criteria	
Discharge Level (kV)	Polarity (+/-)	Test Point	Contact Discharge	Air Discharge
2,4,8	+/-	1	N/A	TT/TR
2,4	+/-	2	TT/TR	N/A

Remark:
Test points : 1. All Exposed Surface & Seams; 2. All metallic part
N/A: Not applicable.

Air discharge ○

Contact discharge △

Discharge Points

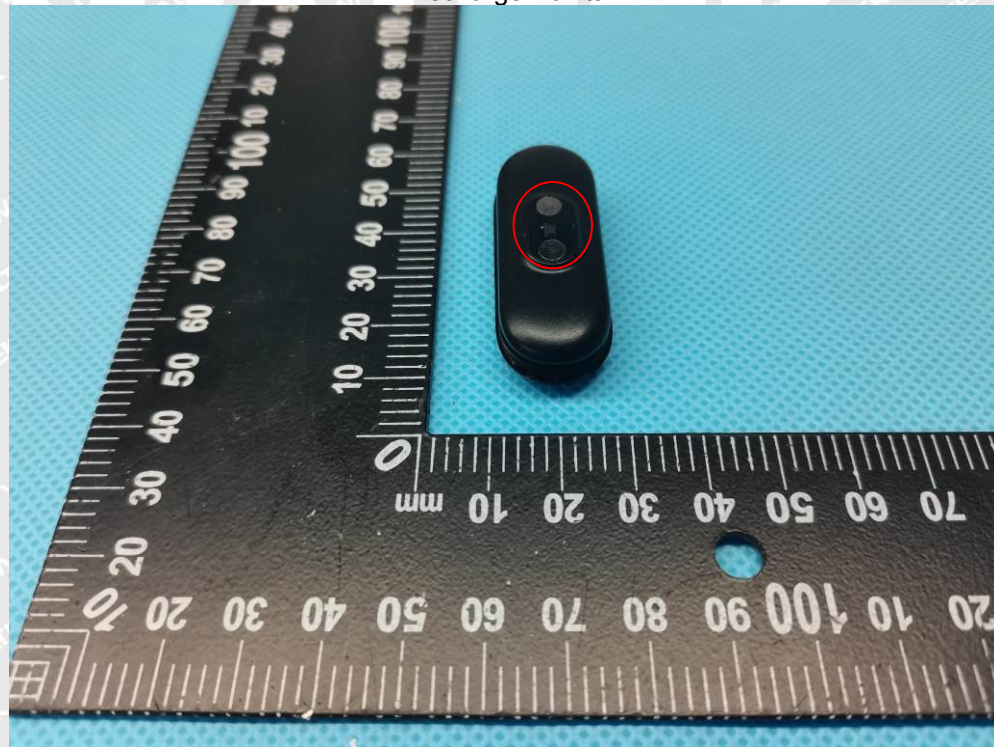

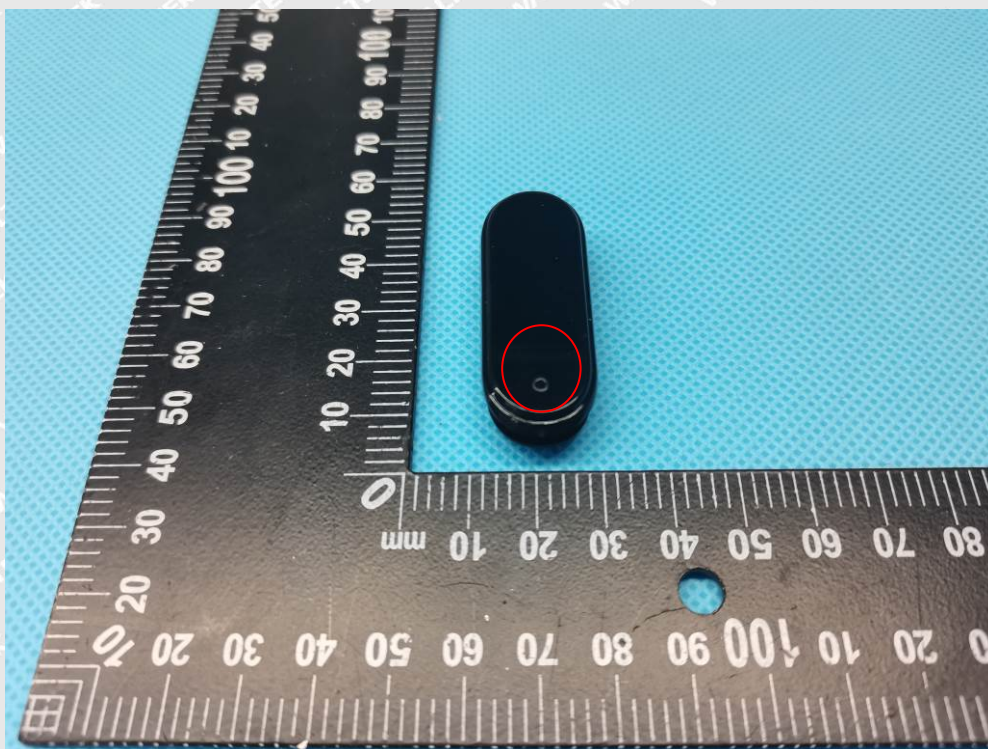

WALTEK



8.3 Radiated Immunity(R/S)

Test Method	: EN 301 489-1, EN 61000-4-3
Face Under Test	: Three Mutually Orthogonal Faces
Severity	: 3V/m, 1kHz, 80% Amp. Mod. from 80MHz to 3GHz, 3GHz to 6GHz
Test Result	: PASS

8.3.1 E.U.T. Operation

Operating Environment:

Temperature	: 21.4°C
Humidity	: 52.1 % RH
Barometric Pressure	: 101.2kPa
EUT Operation :	
Refer to section 7.5.	

8.3.2 Block Diagram of Setup

The Radiated Immunity test was performed in accordance with the EN 61000-4-3.

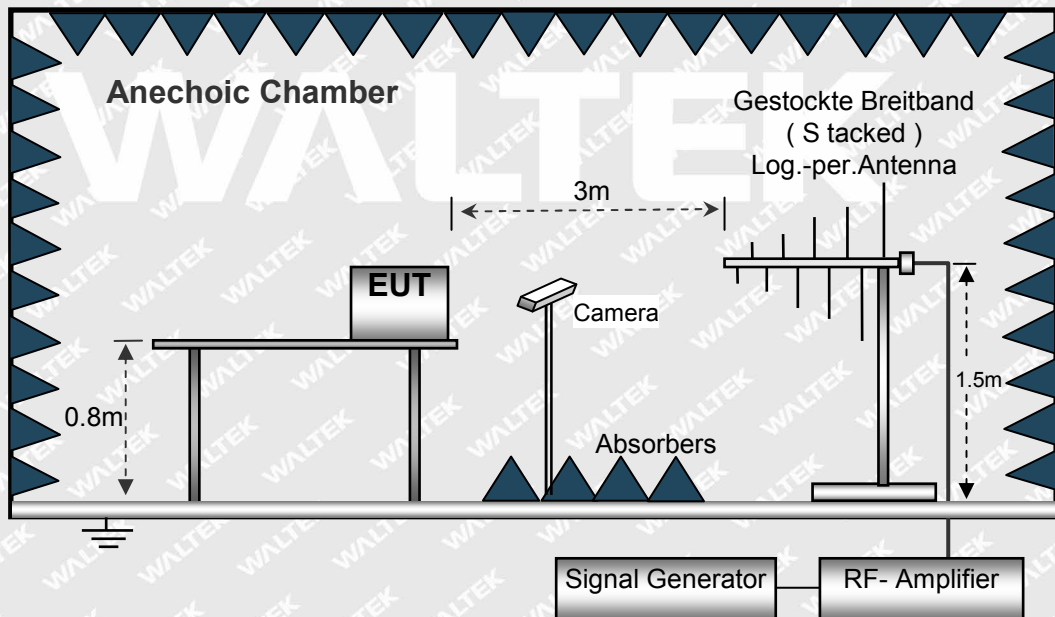



8.3.3 Test Results

Frequency	Level	Modulation	EUT Face	Performance Criteria	BER
80MHz -3GHz,	3V/m	1kHz, 80%, Amp. Mod.	Front, Back Left, Right	CT/CR	0.000%
3GHz - 6GHz	3V/m	1kHz, 80%, Amp. Mod.	Front, Back Left, Right	CT/CR	0.000%

Note 1: The stepped frequency increments may be 50 kHz increment of the momentary frequency in the frequency range 150 kHz to 5 MHz. When using the max hold detector method, initially at each test frequency step an unmodulated immunity test signal shall be applied. Then the modulation of the immunity RF test signal (1 kHz tone) shall be applied as specified in the EN 301 489-1 [1].

Note 2: The receiver mode, BER was recorded during test.

WALTEK



9 Photographs – Test Setup

9.1 Photograph - Radiated Emissions Test Setup

For 30MHz-1000MHz

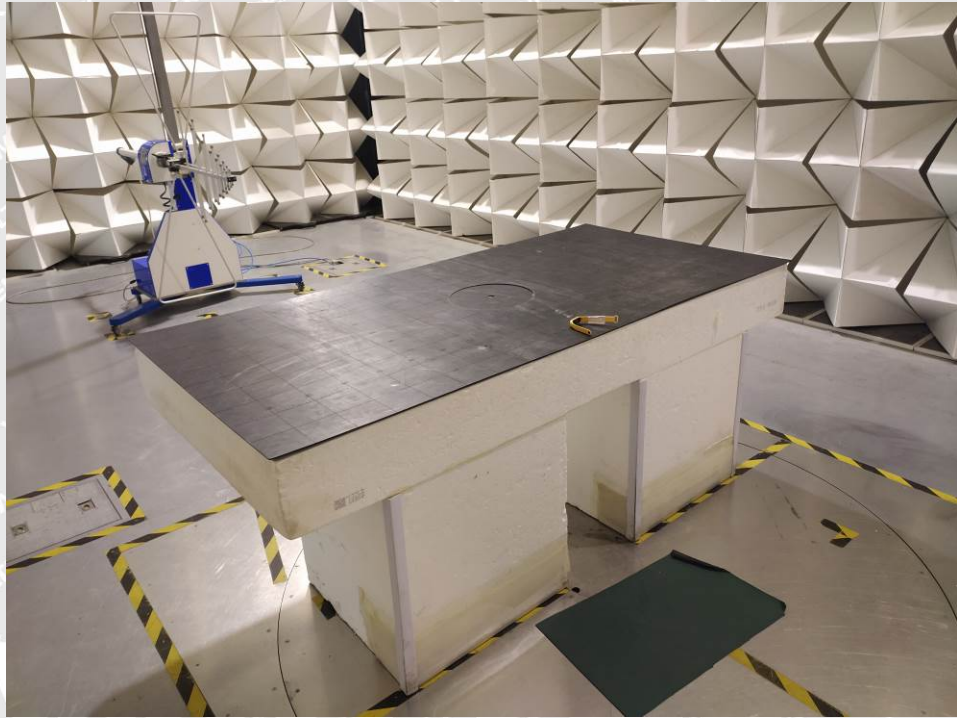

For Above 1GHz

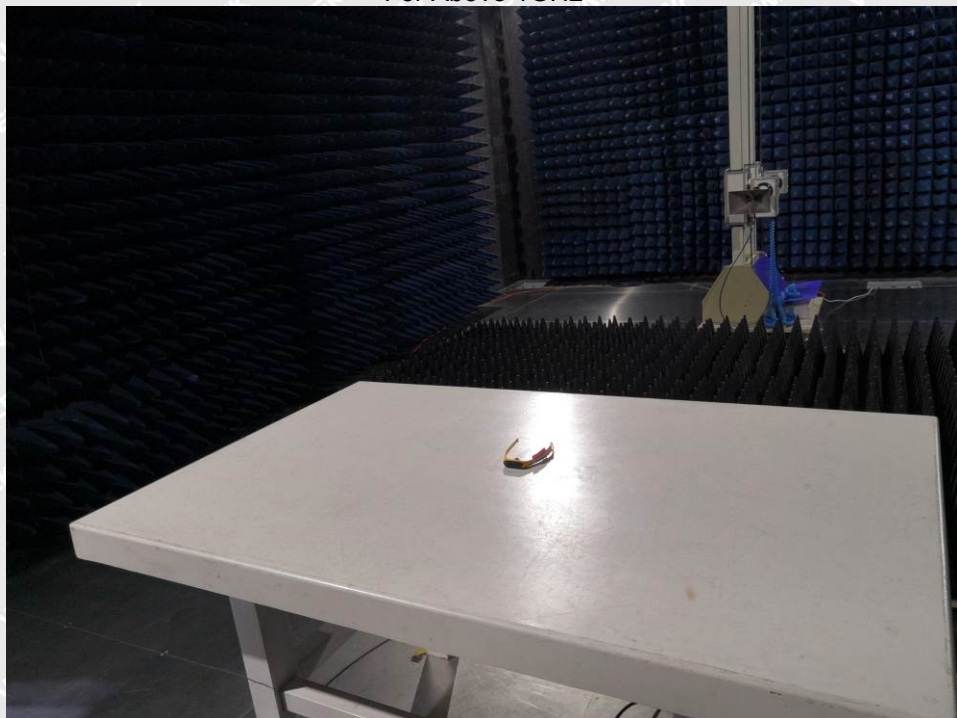



9.2 Photograph - Radiated immunity Test Setup



9.3 Photograph - ESD Test Setup

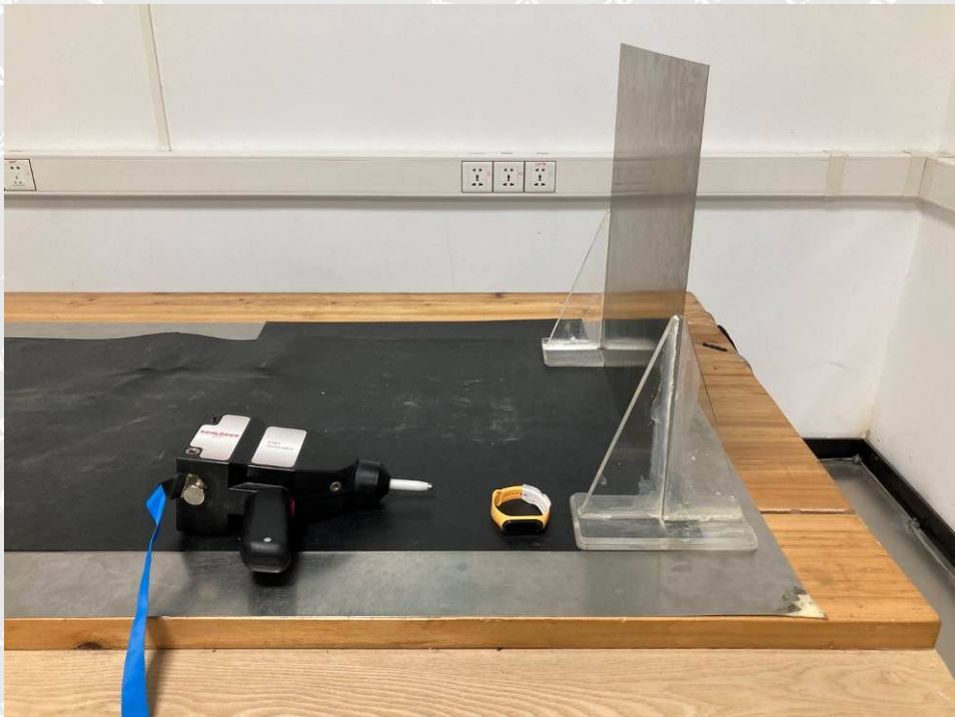



10 Photographs of EUT

10.1 EUT- AppearanceView

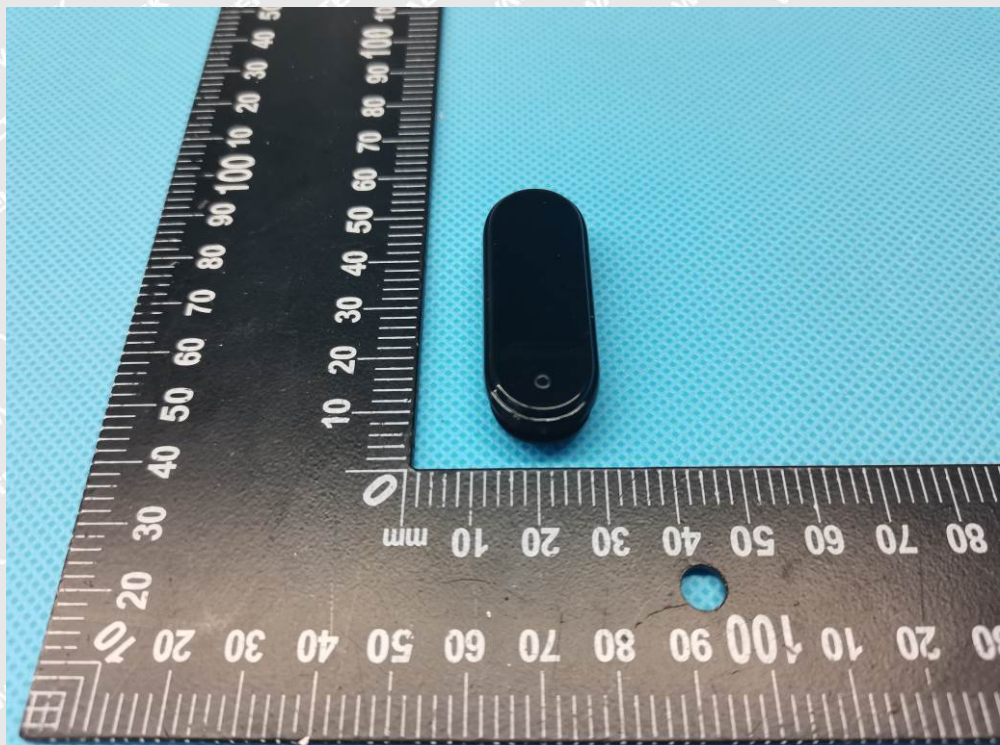
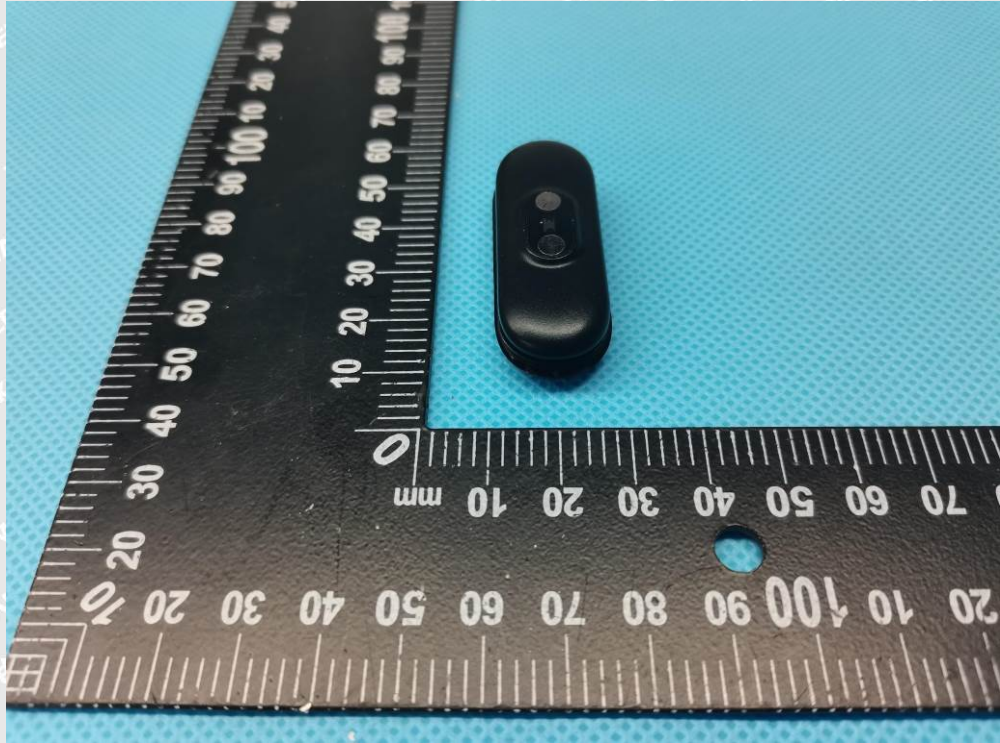

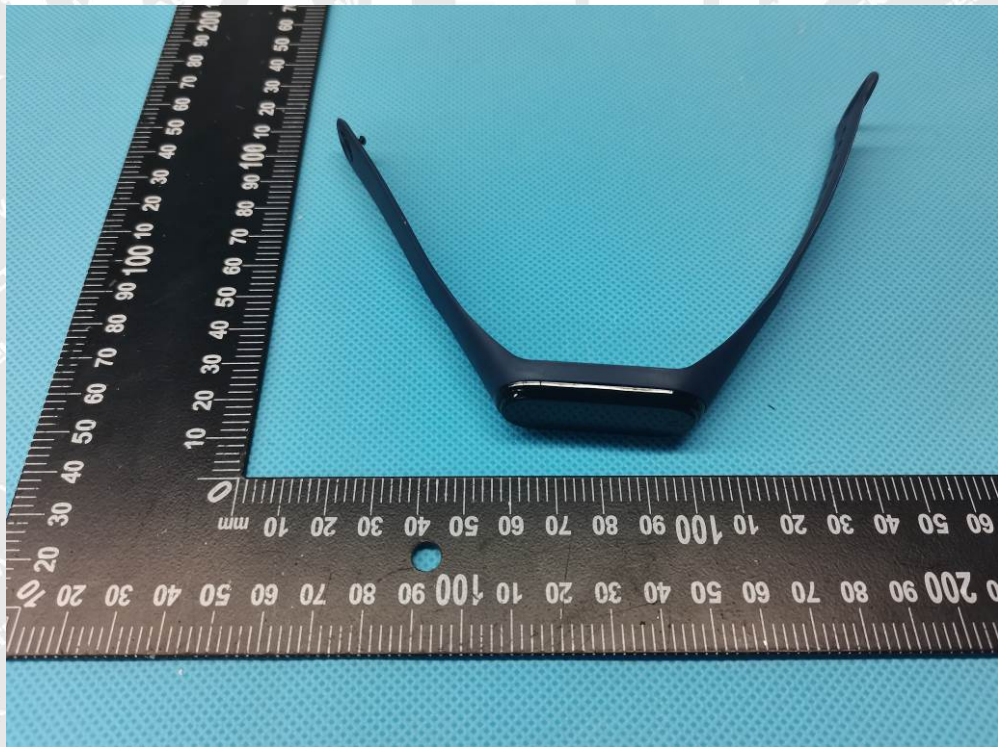
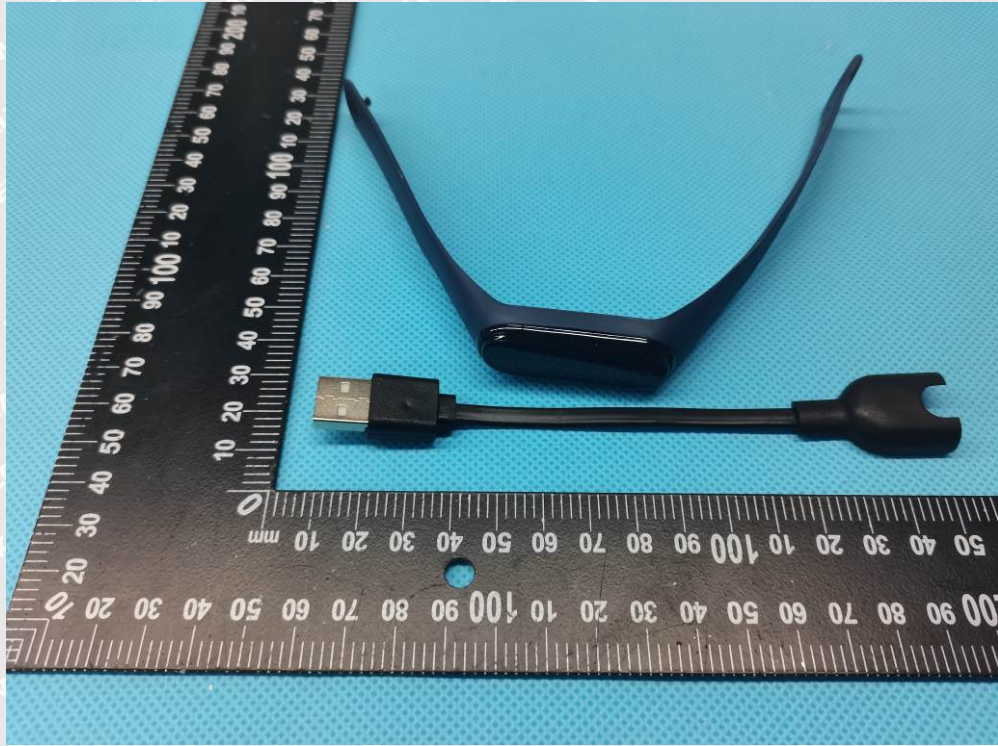

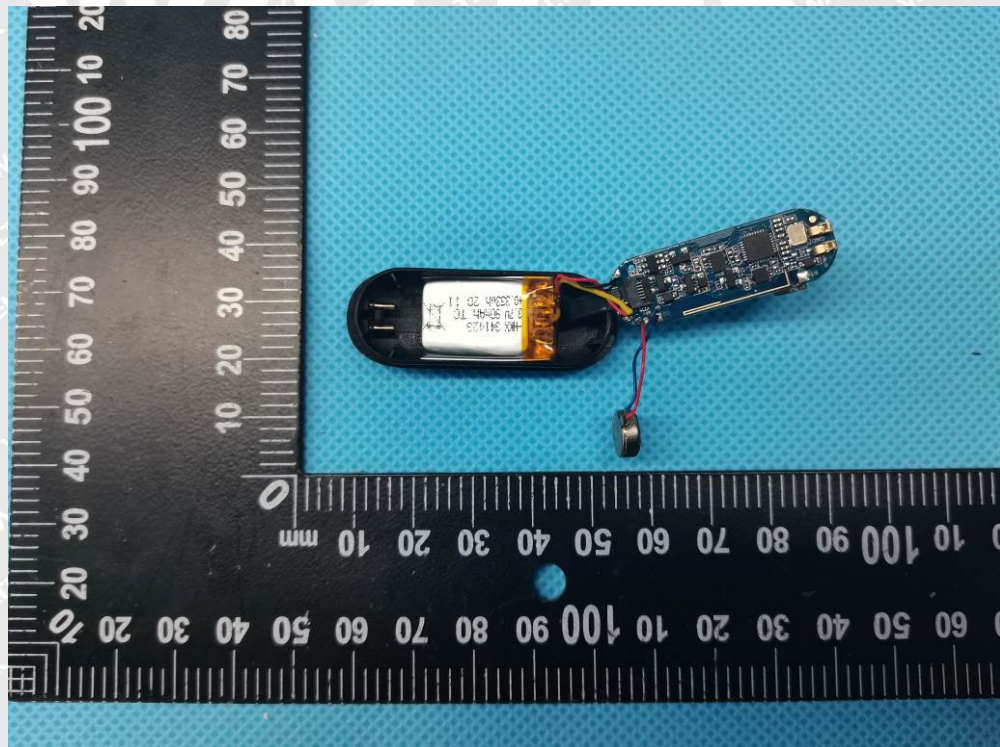



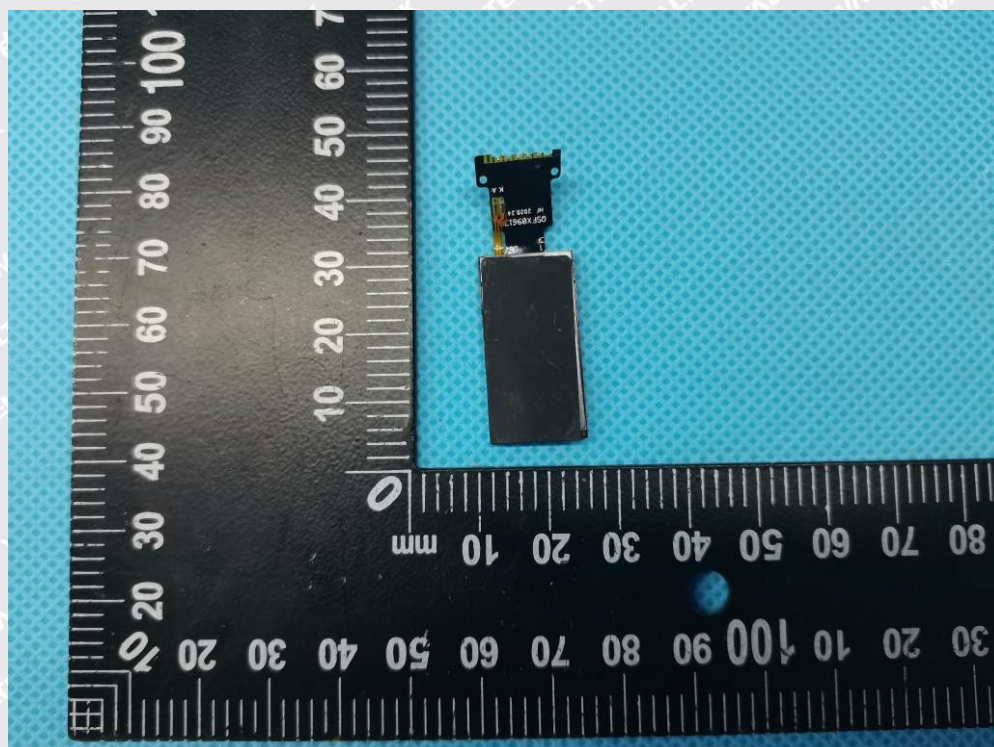
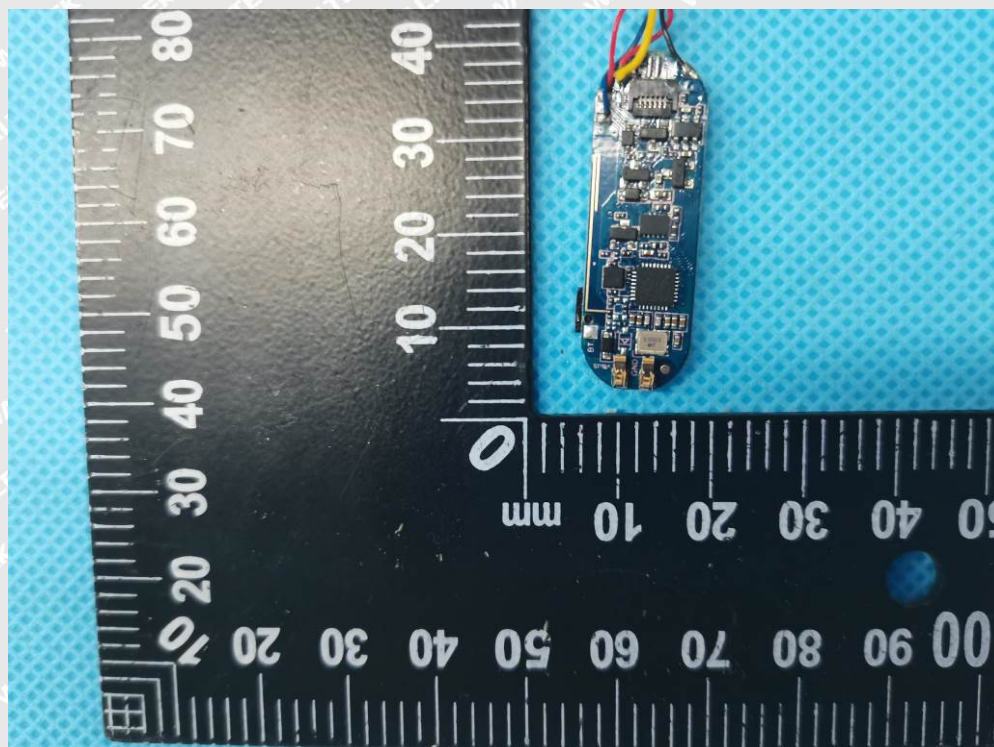

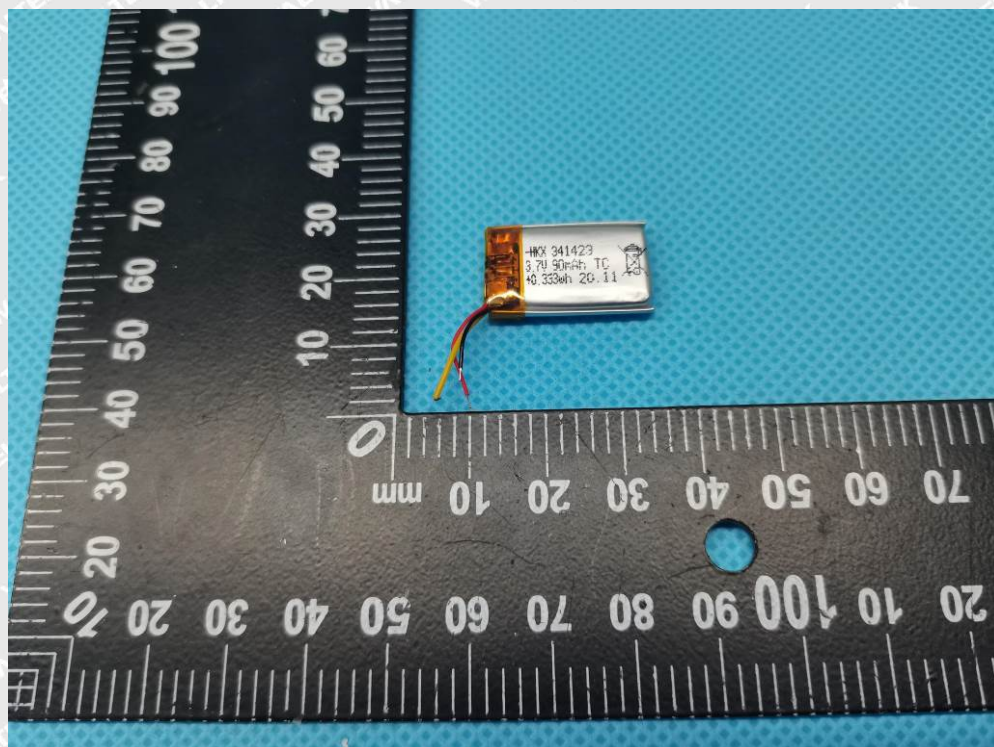
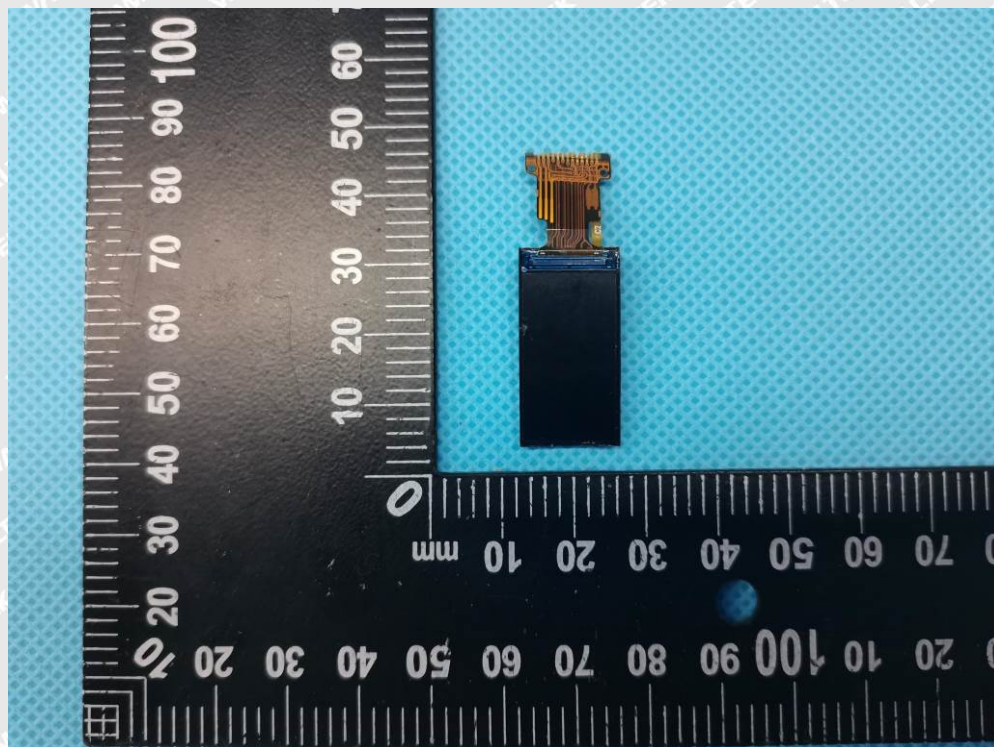

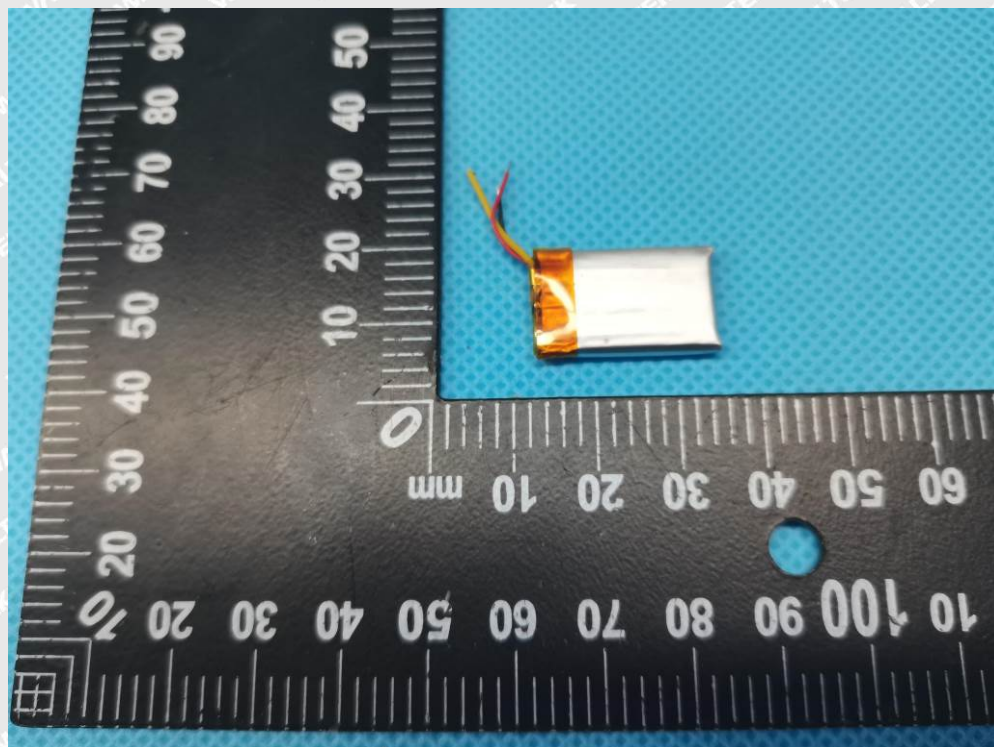

====End of Report====

WALTEK



中国认可
国际互认
检测
TESTING
CNAS L3110



TEST REPORT

Reference No...... : WTF21D01009789E
Manufacturer*..... : Mid Ocean Brands B.V.
Address..... : 7/F., Kings Tower, 111 King Lam Street, Cheung Sha Wan, Kowloon,
Hong Kong
Factory..... : 109328
Product..... : Health bracelet
Model(s)..... : MO6195
Standards..... : EN 55032:2015
EN 55035:2017
EN IEC 61000-3-2:2019
EN 61000-3-3:2013+A1:2019
Date of Receipt sample ... : 2021-02-01
Date of Test..... : 2021-02-01 to 2021-02-08
Date of Issue..... : 2021-02-25
Test Result..... : **Pass**

Remarks:

1. The results shown in this test report refer only to the sample(s) tested, this test report cannot be reproduced, except in full, without prior written permission of the company. The report would be invalid without specific stamp of test institute and the signatures of compiler and approver.
2. "*" **manufacturer** means any natural or legal person who manufactures radio equipment or has radio equipment designed or manufactured, and markets that equipment under his name or trade mark.

Prepared By:

Waltek Testing Group Co., Ltd.

Address: No. 77, Houjie Section, Guantai Road, Houjie Town, Dongguan City, Guangdong, China

Tel: +86-769-2267 6998

Fax: +86-769-2267 6828

Compiled by:

Approved by:

Andy Feng / Project Engineer

Ford Wang / Designated Reviewer



1 Contents

	Page
COVER PAGE	1
1 CONTENTS	2
2 REVISION HISTORY	3
3 GENERAL INFORMATION	4
3.1 GENERAL DESCRIPTION OF E.U.T	4
3.2 DETAILS OF E.U.T	4
3.3 SUBCONTRACTED	4
3.4 ABNORMALITIES FROM STANDARD CONDITIONS	4
4 TEST SUMMARY	5
5 EQUIPMENT USED DURING TEST	6
5.1 EQUIPMENT LIST	6
5.2 DESCRIPTION OF SUPPORT UNITS	7
5.3 MEASUREMENT UNCERTAINTY	7
5.4 TEST EQUIPMENT CALIBRATION	7
5.5 TEST MODE	7
6 EMISSION TEST RESULTS	8
6.1 RADIATED EMISSIONS,30-1000MHZ	8
6.2 RADIATION EMISSION, ABOVE 1000MHZ	11
7 IMMUNITY TEST RESULTS	15
7.1 PERFORMANCE CRITERIA	15
7.2 ELECTROSTATIC DISCHARGE (ESD)	16
7.3 RADIO-FREQUENCY ELECTROMAGNETIC FIELDS	19
8 PHOTOGRAPHS–TEST SETUP	21
8.1 PHOTOGRAPH–RADIATIONEMISSION TEST SETUP 30MHZ-1000MHZ	21
8.2 PHOTOGRAPH– RADIATIONEMISSION TEST SETUP ABOVE 1GHZ	21
8.3 PHOTOGRAPH – ESD IMMUNITY TEST SETUP	22
8.4 PHOTOGRAPH –RADIO-FREQUENCY ELECTROMAGNETIC FIELDS TEST SETUP	22
9 PHOTOGRAPHS–CONSTRUCTIONAL DETAILS	23
9.1 EUT– APPEARANCEVIEW	23



2 Revision History

Test report No.	Date of Receipt sample	Date of Test	Date of Issue	Purpose	Comment	Approved
WTF21D01009789E	2021-02-01	2021-02-01 to 2021-02-08	2021-02-25	Original	-	Valid

WALTEK



3 General Information

3.1 General Description of E.U.T.

Product : Health bracelet
Model(s) : MO6195
Model Difference : N/A
Remark : N/A

3.2 Details of E.U.T.

Ratings : Input: 5V 
Battery: 3.7 , 90mAh

3.3 Subcontracted

Whether parts of tests for the product have been subcontracted to other labs:

Yes No

If Yes, list the related test items and lab information:

Test Lab:N/A

Lab address:N/A

Test items: N/A

3.4 Abnormalities from Standard Conditions

None.



4 Test Summary

EMISSION(EN 55032)		
Test Item	Test Standard	Result
Conducted Emissions from the AC mains power ports 150KHz to 30MHz	EN 55032: 2015	N/A
Asymmetric Mode Conducted Emissions 150KHz to 30MHz	EN 55032: 2015	N/A
Conducted Differential Voltage Emissions 30MHz to 2150MHz	EN 55032: 2015	N/A
Radiated Emissions, 30MHz to 1000MHz	EN 55032: 2015	Pass
Radiated Emissions, Above 1GHz	EN 55032: 2015	Pass
Harmonic Current	EN IEC 61000-3-2:2019	N/A
Voltage Fluctuation and Flicker	EN 61000-3-3:2019	N/A
IMMUNITY(EN 55035)		
Test Item	Test Method	Result
Electrostatic Discharge(ESD)	IEC 61000-4-2:2008	Pass
Radiation Immunity	IEC 61000-4-3:2010	Pass
Electrical Fast Transients (EFT)	IEC 61000-4-4:2012	N/A
Surges	IEC 61000-4-5:2005	N/A
Injected Currents	IEC 61000-4-6:2008	N/A
Power-frequency magnetic fields	IEC 61000-4-8:2009	N/A*
Voltage Dips and Voltage interruptions	IEC 61000-4-11:2004	N/A

Remark:

Pass

Fail

N/A

*

Test item meets the requirement

Test item does not meet the requirement

Test case does not apply to the test object

Applicable only to equipment containing devices intrinsically susceptible to magnetic fields, such as CRT monitors, Hall effect elements, electro-dynamic microphones, magnetic field sensors or audio frequency transformers.



5 Equipment Used during Test

5.1 Equipment List

3m Semi-anechoic Chamber for Radiation (Below 1GHz) TDK						
Item	Equipment	Manufacturer	Model No.	Serial No.	Last Calibration Date	Calibration Due Date
1	Test Receiver	R&S	ESCI	101296	2020.04.20	2021.04.19
2	Trilog Broadband Antenna	SCHWARZBECK	VULB9160	9160-3325	2020.04.25	2021.04.24
3	Amplifier	ANRITSU	MH648A	M43381	2020.04.20	2021.04.19
4	Cable	HUBER+SUHNER	CBL2	525178	2020.04.20	2021.04.19
3m Fully Anechoic Room for Radiation (Above 1GHz)						
Item	Equipment	Manufacturer	Model No.	Serial No.	Last Calibration Date	Calibration Due Date
1	Spectrum Analyzer	R&S	FSP	100091	2020.04.20	2021.04.19
2	Broad-band Horn Antenna	SCHWARZBECK	BBHA 9120 D	667	2020.04.25	2021.04.24
3	Broadband Preamplifier	COMPLIANCE DIRECTION	PAP-1G18	2004	2020.04.20	2021.04.19
4	Coaxial Cable (above 1GHz)	Top	1GHz-18GHz	NA	2020.04.20	2021.04.19
Electrostatic Discharge						
Item	Equipment	Manufacturer	Model No.	Serial No.	Last Calibration Date	Calibration Due Date
1	Electrostatic Discharge Simulator	SCHLODER	SESD 216	606144	2020.04.24	2021.04.23
Radio-frequency electromagnetic fields						
Item	Equipment	Manufacturer	Model No.	Serial No.	Last Calibration Date	Calibration Due Date
1	Signal Generator	R&S	SMB100A	105942	2020.07.30	2021.07.29
2	RF Power Amplifier	BONN Elektronik	BLWA0830-160/100/40D	128740	2020.07.30	2021.07.29
3	Gestockte Breitband (S tacked) Log.-per. Antenna	SCHWARZBECK	STLP9128D	043	2020.07.30	2021.07.29
4	Power Meter	R&S	NRP2	102031	2020.04.20	2021.04.19
5	Amplifier	NJNT	NTWPAS-2560025	2560025	2020.04.20	2021.04.19



5.2 Description of Support Units

Equipment	Manufacturer	Model No.	Series No.
/	/	/	/

5.3 Measurement Uncertainty

Parameter	Uncertainty (Note 1)
Temperature	$\pm 1^{\circ}\text{C}$
Humidity	$\pm 5\%$
DC and low frequency voltages	$\pm 3\%$
Conducted Emission (150kHz-30MHz)	$\pm 3.64\text{dB}$
Radiated Emission(30MHz-1000MHz)	$\pm 5.03\text{dB}$
Radiated Emission(1GHz~18GHz)	$\pm 5.47\text{dB}$

Note 1: This uncertainty represents an expanded uncertainty expressed at approximately the 95% confidence level using a coverage factor of $k=2$.

5.4 Test Equipment Calibration

All the test equipments used are valid and calibrated by GUANG ZHOU GRG METROLOGY & TEST CO., LTD. address is No.163, Pingyun Rd. West of Huangpu Ave, Tianhe District, Guangzhou, Guangdong, China.

5.5 Test Mode

Radiated Emissions	
TM1*	Charging mode
Electrostatic Discharge(ESD)	
TM1*	Charging mode
Radiated Immunity(R/S)	
TM1*	Charging mode
** shows the worst case mode which were recorded in this report.	



6 Emission Test Results

6.1 Radiated Emissions,30-1000MHz

Test Requirement..... : EN 55032

Test Method..... : EN 55032

Frequency Range..... : 30MHz to 1000MHz

Class/Severity..... : Class B/ Table A.4 of EN 55032

Test Result : Pass Fail not applicable (Remark)

6.1.1E.U.T. Operation

Operating Environment:

Temperature..... : 23.1°C

Humidity..... : 54.8%RH

Atmospheric Pressure..... : 101.5kPa

EUT Operation..... : Refer to section 5.5.

6.1.2Block Diagram of Test Setup

The RadiationEmissiontest was performed in accordance with EN 55032.

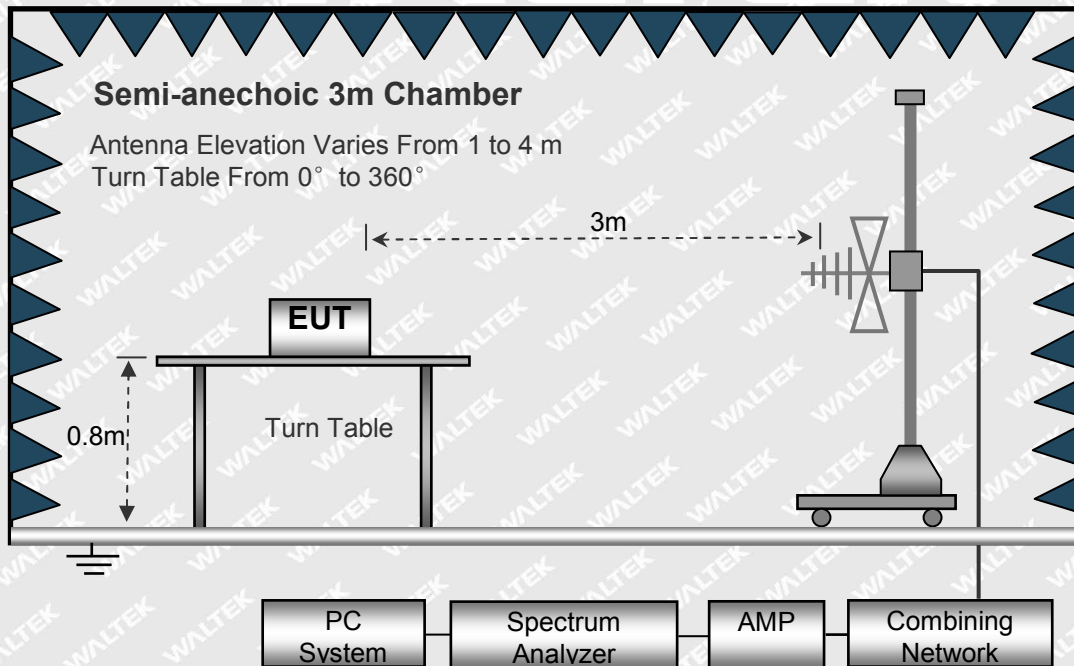



6.1.3 Measurement Data

The maximised peak emissions from the EUT was scanned and measured for both the Antenna Vertical Polarization and Antenna Horizontal Polarization. Quasi-peak measurements were performed if peak emissions were within 6dB of the Quasi-peak limit line.

6.1.4 Corrected Amplitude & Margin Calculation

The Corrected Amplitude is calculated by adding the Antenna Factor and Cable Factor, and subtracting the Amplifier Gain from the Amplitude reading. The basic equation is as follows:

$$\text{Corr. Ampl.} = \text{Indicated Reading} + \text{Antenna Factor} + \text{Cable Factor} - \text{Amplifier Gain}$$

The “Margin” column of the following data tables indicates the degree of compliance with the applicable limit. For example, a margin of -6dB means the emission is 6dB below the maximum limit. The equation for margin calculation is as follows:

$$\text{Margin} = \text{Corr. Ampl.} - \text{Limit}$$

6.1.5 Test Data

Antenna Polarization: Vertical

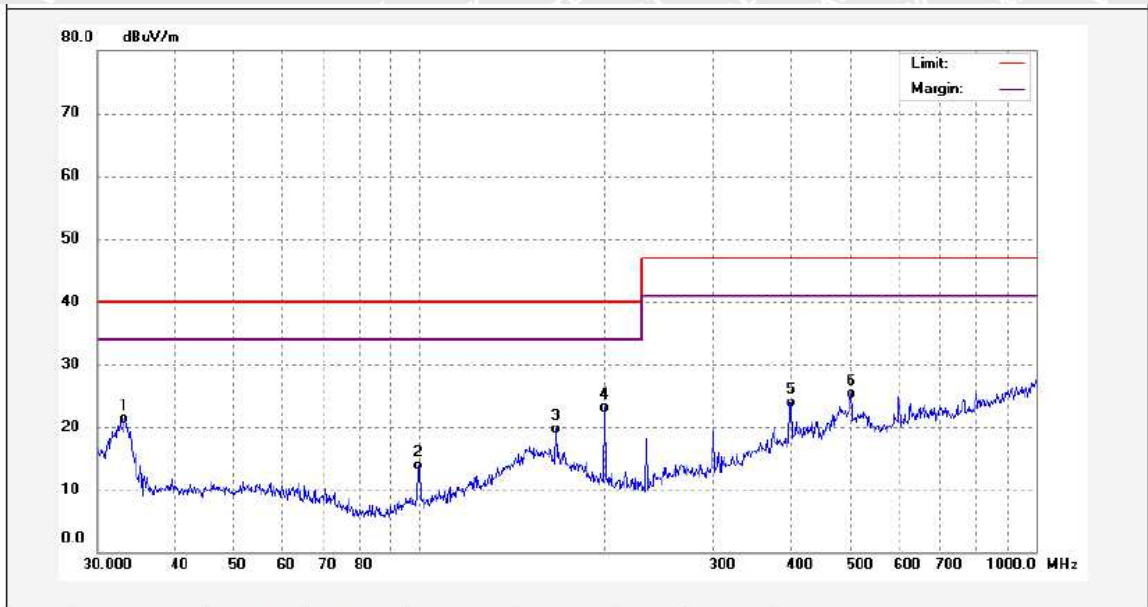

No.	Freq. (MHz)	Reading (dBuV/m)	Factor (dB)	Result (dBuV/m)	Limit (dBuV/m)	Margin (dB)	Detector	Remark
1	33.0949	39.30	-18.04	21.26	40.00	-18.74	QP	
2	99.5281	33.36	-19.44	13.92	40.00	-26.08	QP	
3	166.0680	35.37	-15.69	19.68	40.00	-20.32	QP	
4	199.9855	41.35	-18.26	23.09	40.00	-16.91	QP	
5	400.4318	36.43	-12.45	23.98	47.00	-23.02	QP	
6	501.1790	35.24	-10.01	25.23	47.00	-21.77	QP	



Antenna Polarization: Horizontal

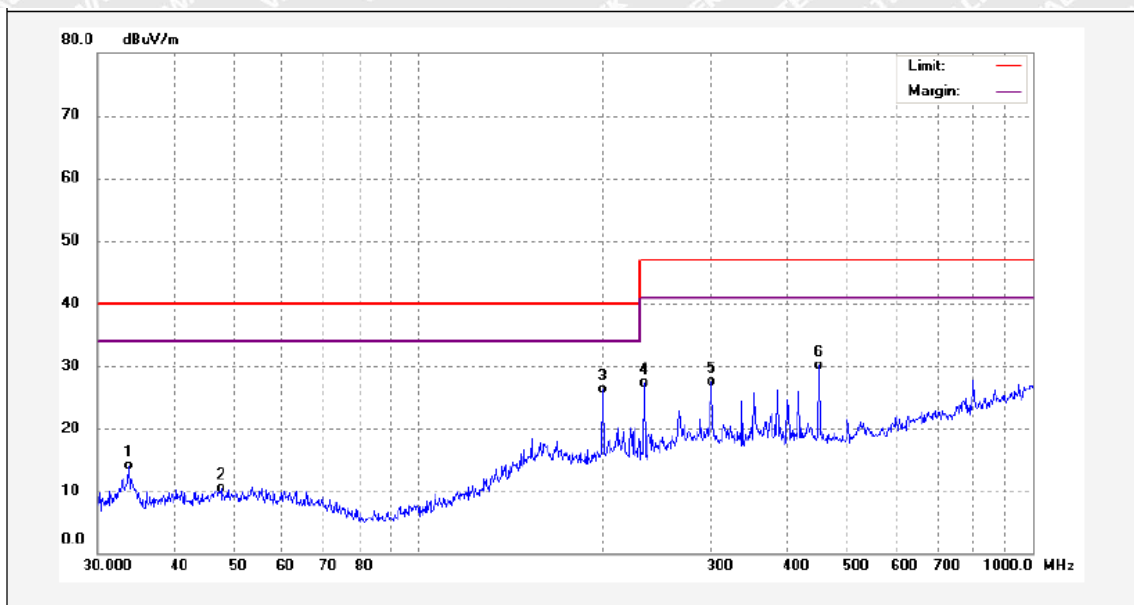

No.	Freq. (MHz)	Reading (dBuV/m)	Factor (dB)	Result (dBuV/m)	Limit (dBuV/m)	Margin (dB)	Detector	Remark
1	33.7986	32.08	-18.01	14.07	40.00	-25.93	QP	
2	47.6586	27.55	-17.07	10.48	40.00	-29.52	QP	
3	199.2855	44.56	-18.23	26.33	40.00	-13.67	QP	
4	232.5318	44.86	-17.65	27.21	47.00	-19.79	QP	
5	299.3158	42.16	-14.72	27.44	47.00	-19.56	QP	
6	447.9822	41.49	-11.38	30.11	47.00	-16.89	QP	



6.2 Radiation Emission, Above 1000MHz

Test Requirement..... : EN 55032
 Test Method..... : EN 55032
 Frequency Range..... : Above 1000MHz
 Class/Severity..... : Class B/ Table A.5 of EN 55032
 Test Result : Pass Fail not applicable (Remark)

6.2.1E.U.T. Operation

Operating Environment:

Temperature..... : 23.5°C
 Humidity..... : 52.3%RH
 Atmospheric Pressure..... : 101.3kPa
 EUT Operation..... : Refer to section 5.5.

6.2.2Block Diagram of Test Setup

The RadiationEmissiontest was performed in accordance with EN 55032.

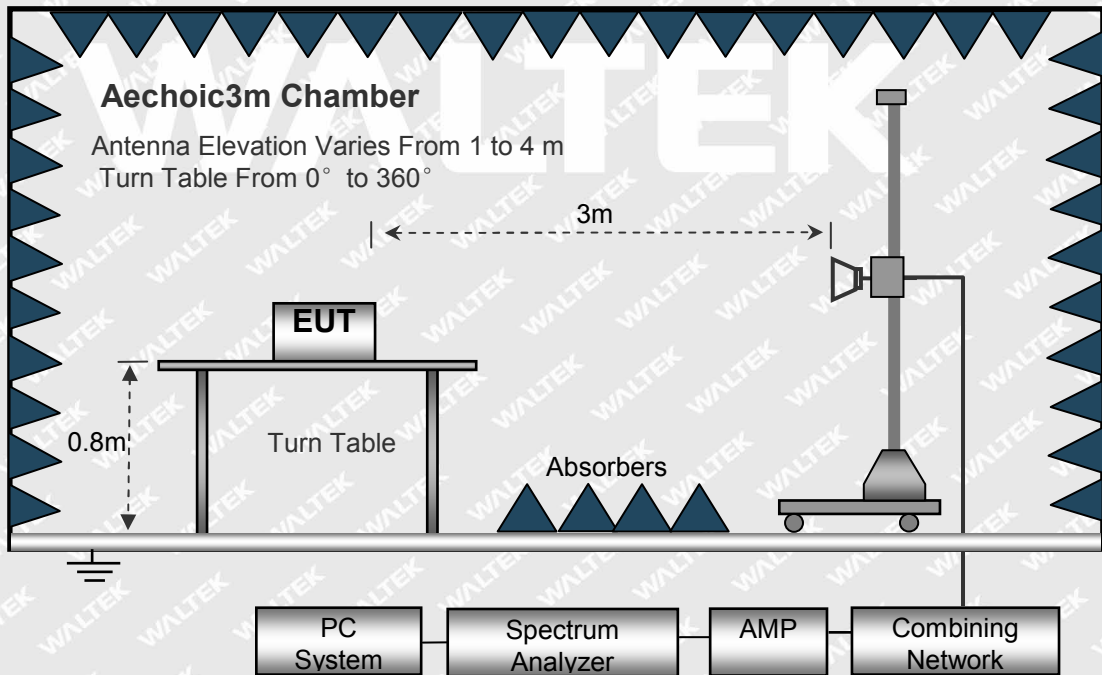

6.2.3Measurement Data

The maximised peak emissions from the EUT was scanned and measured for both the Antenna Vertical Polarization and Antenna Horizontal Polarization. Average measurements were performed if peak emissions were within 6dB of the average limit line.

The test Frequency range judgment basis:

If the highest frequency of the internal sources of the EUT is less than 108 MHz, the



measurement shall only be made up to 1 GHz.

If the highest frequency of the internal sources of the EUT is between 108 MHz and 500 MHz, the measurement shall only be made up to 2 GHz.

If the highest frequency of the internal sources of the EUT is between 500 MHz and 1 GHz, the measurement shall only be made up to 5 GHz.

If the highest frequency of the internal sources of the EUT is above 1 GHz, the measurement shall be made up to 5 times the highest frequency or 6 GHz, whichever is less.

6.2.4 Corrected Amplitude & Margin Calculation

The Corrected Amplitude is calculated by adding the Antenna Factor and Cable Factor, and subtracting the Amplifier Gain from the Amplitude reading. The basic equation is as follows:

$$\text{Corr. Ampl.} = \text{Indicated Reading} + \text{Antenna Factor} + \text{Cable Factor} - \text{Amplifier Gain}$$

The “**Margin**” column of the following data tables indicates the degree of compliance with the applicable limit.

For example, a margin of -6dB means the emission is 6dB below the maximum limit. The equation for margin calculation is as follows:

$$\text{Margin} = \text{Corr. Ampl.} - \text{Limit}$$

WALTEK



6.2.5 Test Data

Antenna Polarization: Vertical

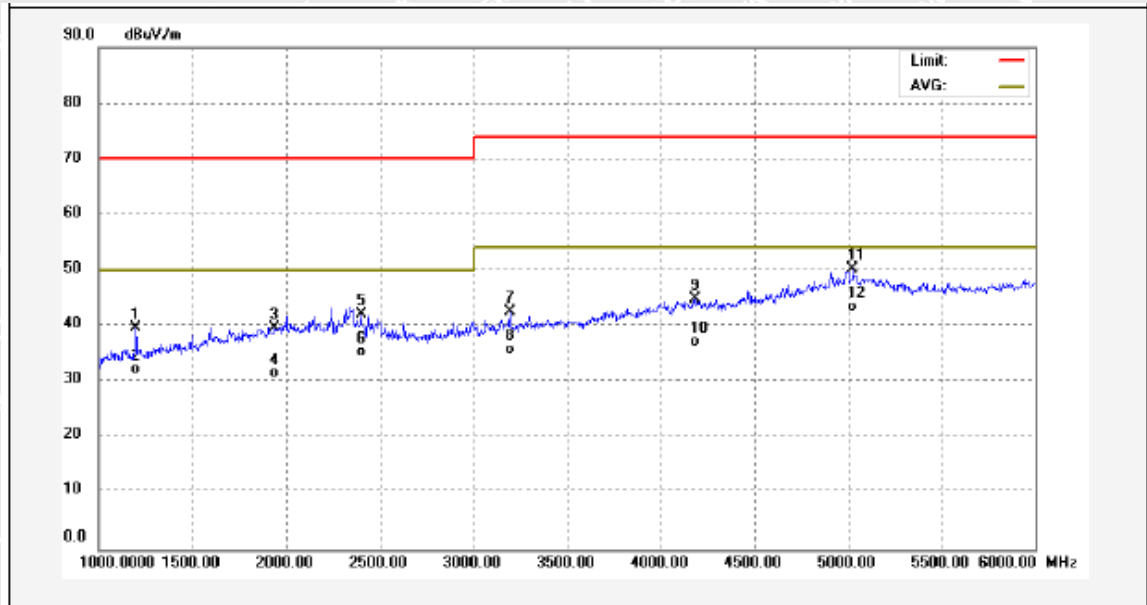

No.	Freq. (MHz)	Reading (dBuV/m)	Factor (dB)	Result (dBuV/m)	Limit (dBuV/m)	Margin (dB)	Detector	Remark
1	1195.000	55.15	-15.39	39.76	70.00	-30.24	peak	
2	1195.000	47.57	-15.39	32.18	50.00	-17.82	AVG	
3	1935.000	50.60	-10.81	39.79	70.00	-30.21	peak	
4	1935.000	42.35	-10.81	31.54	50.00	-18.46	AVG	
5	2400.000	53.97	-11.84	42.13	70.00	-27.87	peak	
6	2400.000	47.32	-11.84	35.48	50.00	-14.52	AVG	
7	3195.000	52.80	-10.10	42.70	74.00	-31.30	peak	
8	3195.000	46.04	-10.10	35.94	54.00	-18.06	AVG	
9	4180.000	51.05	-6.26	44.79	74.00	-29.21	peak	
10	4180.000	43.44	-6.26	37.18	54.00	-16.82	AVG	
11	5025.000	51.73	-1.45	50.28	74.00	-23.72	peak	
12	5025.000	44.93	-1.45	43.48	54.00	-10.52	AVG	



Antenna Polarization: Horizontal

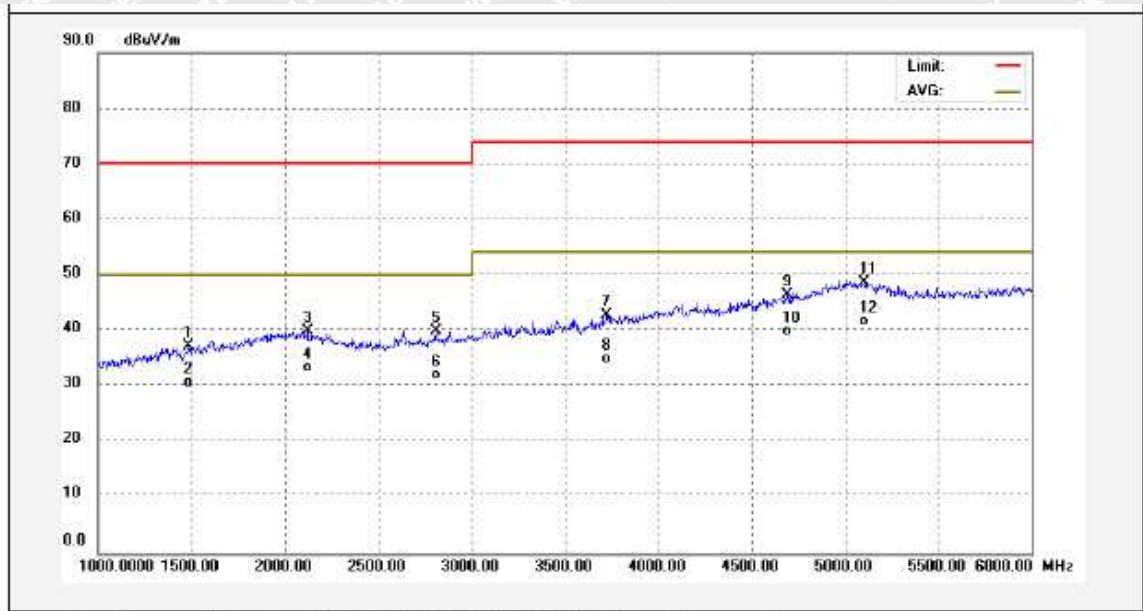

No.	Freq. (MHz)	Reading (dBuV/m)	Factor (dB)	Result (dBuV/m)	Limit (dBuV/m)	Margin (dB)	Detector	Remark
1	1485.000	48.94	-11.70	37.24	70.00	-32.76	peak	
2	1485.000	42.31	-11.70	30.61	50.00	-19.39	AVG	
3	2120.000	48.43	-8.42	40.01	70.00	-29.99	peak	
4	2120.000	41.85	-8.42	33.43	50.00	-16.57	AVG	
5	2810.000	47.48	-7.57	39.91	70.00	-30.09	peak	
6	2810.000	39.72	-7.57	32.15	50.00	-17.85	AVG	
7	3725.000	49.60	-6.80	42.80	74.00	-31.20	peak	
8	3725.000	41.84	-6.80	35.04	54.00	-18.96	AVG	
9	4690.000	51.46	-5.00	46.46	74.00	-27.54	peak	
10	4690.000	44.85	-5.00	39.85	54.00	-14.15	AVG	
11	5105.000	52.56	-3.82	48.74	74.00	-25.26	peak	
12	5105.000	45.66	-3.82	41.84	54.00	-12.16	AVG	



7 Immunity Test Results

7.1 Performance Criteria

Performance criterion A: The apparatus shall continue to operate as intended during the test.

No degradation of performance or loss of function is allowed below a performance level (or permissible loss of performance) specified by the manufacturer, when the apparatus is used as intended. If the minimum performance level or the permissible performance loss is not specified by the manufacturer, then either of these may be derived from the product description and documentation, and from what the user may reasonably expect from the apparatus if used as intended.

Performance criterion B: The apparatus shall continue to operate as intended after the test.

No degradation of performance or loss of function is allowed below a performance level (or permissible loss of performance) specified by the manufacturer, when the apparatus is used as intended. During the test, degradation of performance is allowed, however, no change of actual operating state or stored data is allowed. If the minimum performance level or the permissible performance loss is not specified by the manufacturer, then either of these may be derived from the product description and documentation, and from what the user may reasonably expect from the apparatus if used as intended.

Performance criterion C: Temporary loss of function is allowed, provided the function is self-recoverable or can be restored by the operation of the controls, or by any operations specified in the instructions for use.

For further details, please refer to EN 55035.

WALTEK



7.2 Electrostatic Discharge (ESD)

Test Requirement.....	: EN 55035
Test Method.....	: IEC 61000-4-2
Test Result	: Pass
Discharge Impedance	: 330Ω / 150pF
Discharge Voltage	: Air Discharge: ±8kV Contact Discharge: ±4kV HCP & VCP: ±4kV
Polarity.....	: Positive & Negative
Number of Discharge	: Minimum 50 times at each test point(25 of each polarity)
Discharge Mode	: Single Discharge
Discharge Period.....	: 1 second minimum

7.2.1 E.U.T. Operation

Operating Environment:

Temperature.....	: 22.8°C
Humidity.....	: 54.7%RH
Barometric Pressure.....	: 100.8kPa
EUT Operation.....	: Refer to section 5.5.

7.2.2 Block Diagram of Setup

The ESD test was performed in accordance with the IEC 61000-4-2.

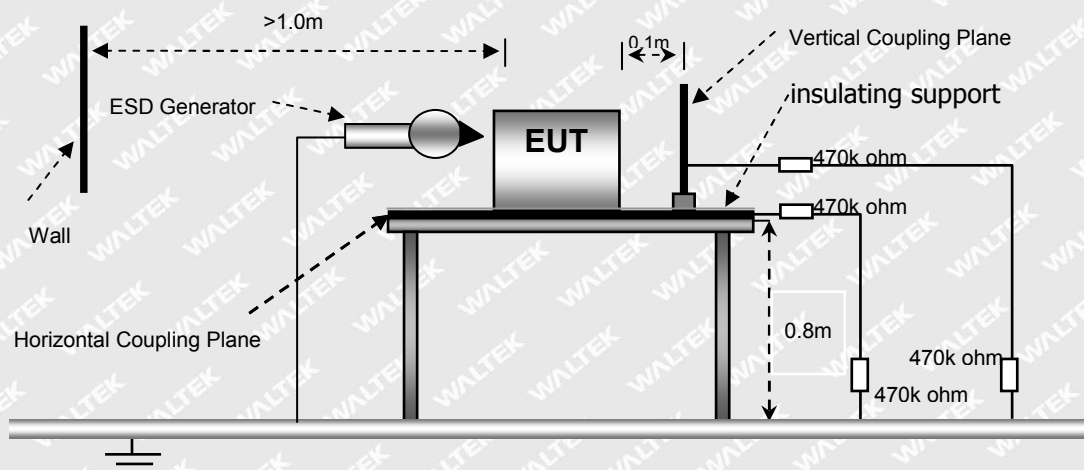



7.2.3 Direct Discharge Test Results

Observations: Test points: 1. All Exposed Surface & Seams;
2. All metallic part

Direct Discharge			Test Results	
Applied Voltage (kV)	Performance Criterion	Test Point	Contact Discharge	Air Discharge
±8	B	1	N/A	Pass
±4	B	2	Pass	N/A

7.2.4 Indirect Discharge Test Results

Observations: Test points: 1. All sides.

Indirect Discharge			Test Results	
Applied Voltage (kV)	Performance Criterion	Test Point	Horizontal Coupling	Vertical Coupling
±4	B	1	Pass	Pass

Air discharge ○

Contact discharge △

Discharge Points

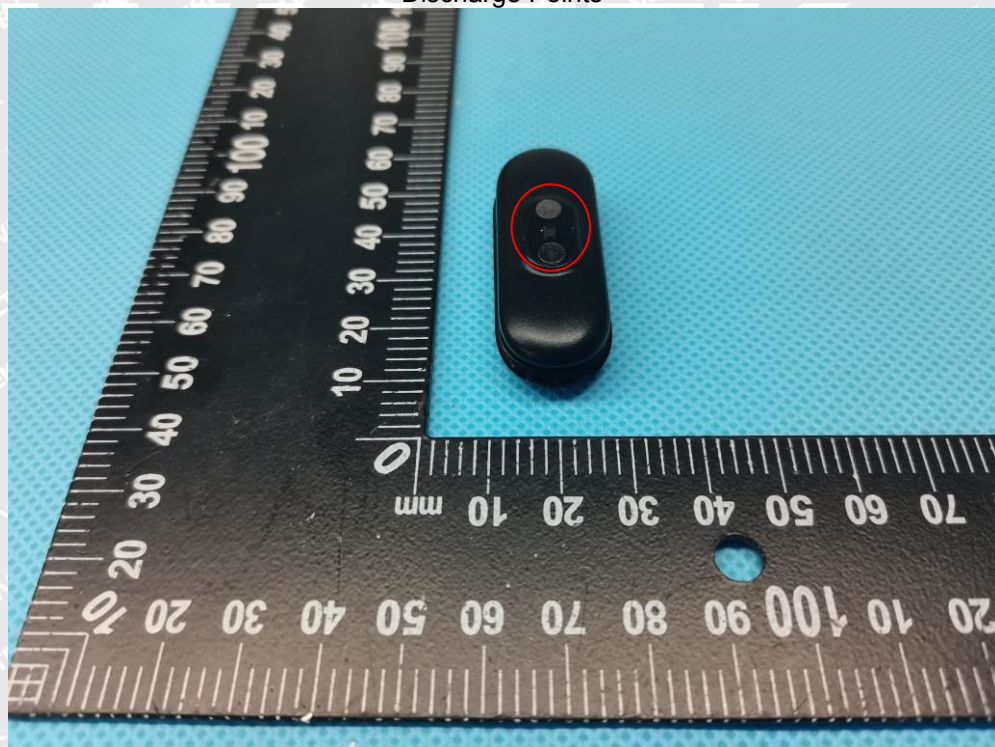

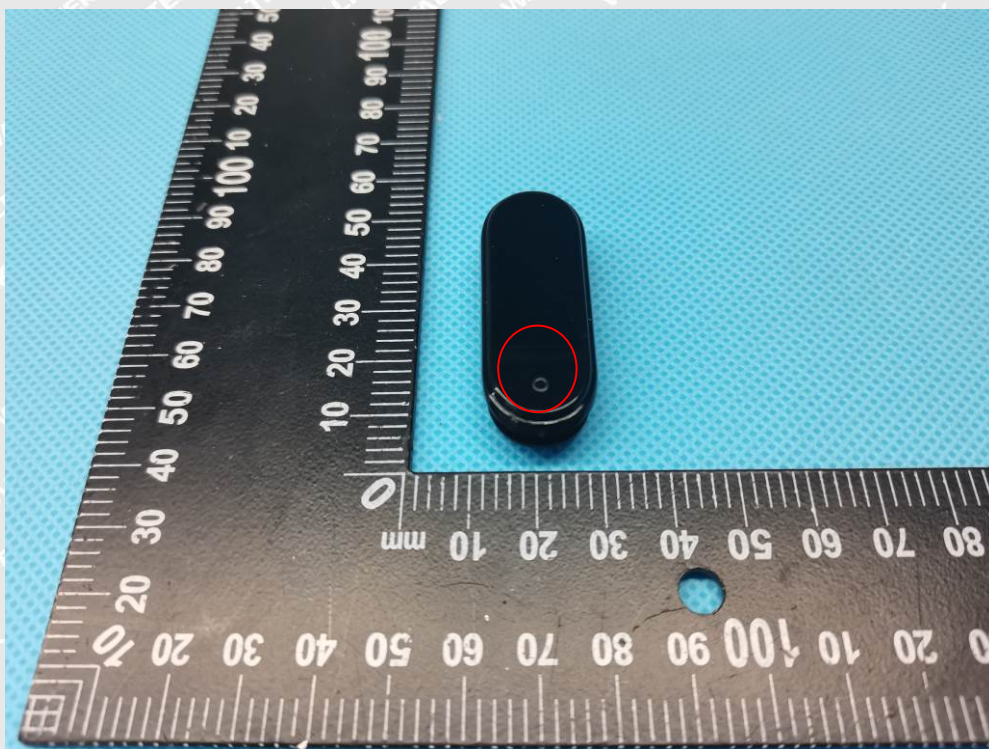

WALTEK



7.3 Radio-frequency electromagnetic fields

Test Requirement.....	: EN 55035
Test Method.....	: IEC 61000-4-3
Test Result	: Pass
FrequencyRange.....	: 80MHz to 1GHz 1.8GHz, 2.6GHz, 3.5GHz, 5GHz
Test level	: 3V/m
Modulation	: 80%, 1kHz Amplitude Modulation.
Face of EUT	: Front, Back, Left, Right
Antenna polarisation.....	: Horizontal&Vertical

7.3.1 E.U.T. Operation

Operating Environment:

Temperature.....	: 21.7°C
Humidity.....	: 52.4% RH
Barometric Pressure.....	: 102.4kPa
EUT Operation.....	: Refer to section 5.5.

7.3.2 Block Diagram of Setup

The Radio-frequency electromagnetic fields Immunity test was performed in accordance with the IEC 61000-4-3.

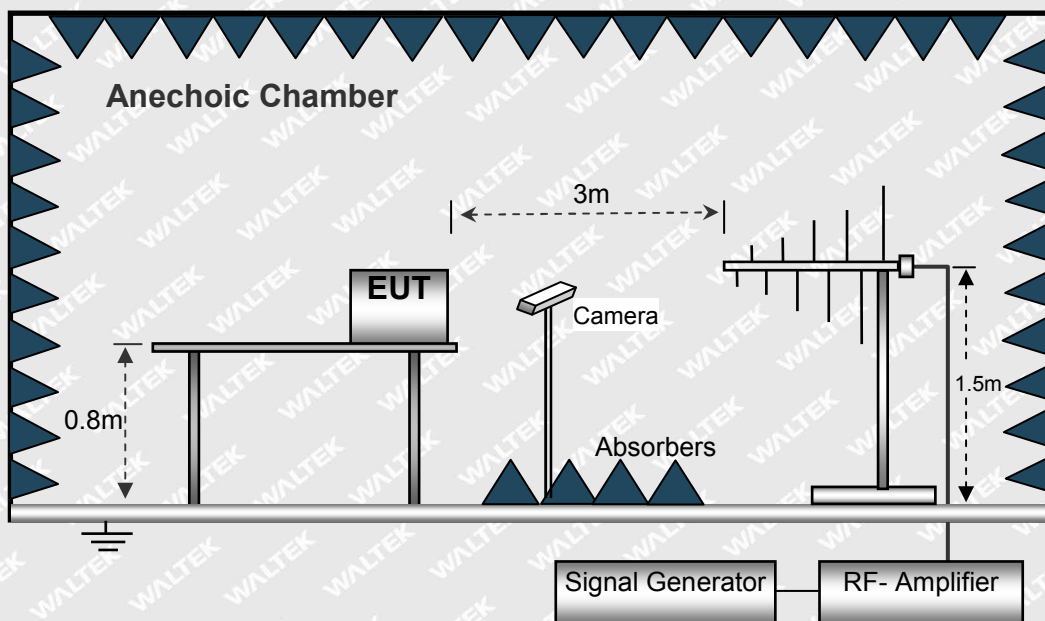



7.3.3 Test Results

Test Frequency (MHz)	Face of EUT	Antenna polarisation	Test Level	Step Size	Dwell Time	Performance Criterion	Result
80-1000MHz 1800MHz, 2600MHz, 3500MHz, 5000MHz	Front, Back, Left, Right	Horizontal	3V/m	1%	1s	A	Pass
	Front, Back, Left, Right	Vertical	3V/m	1%	1s	A	Pass

WALTEK



8 Photographs–Test Setup

8.1 Photograph–RadiationEmission Test Setup 30MHz-1000MHz

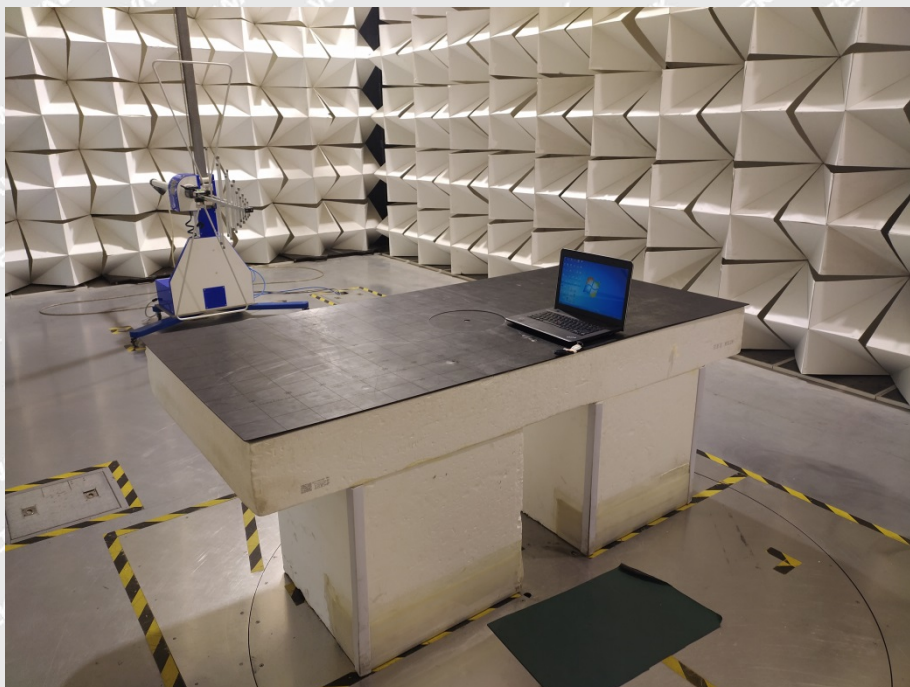

8.2 Photograph– RadiationEmission Test Setup Above 1GHz





8.3 Photograph – ESD Immunity Test Setup

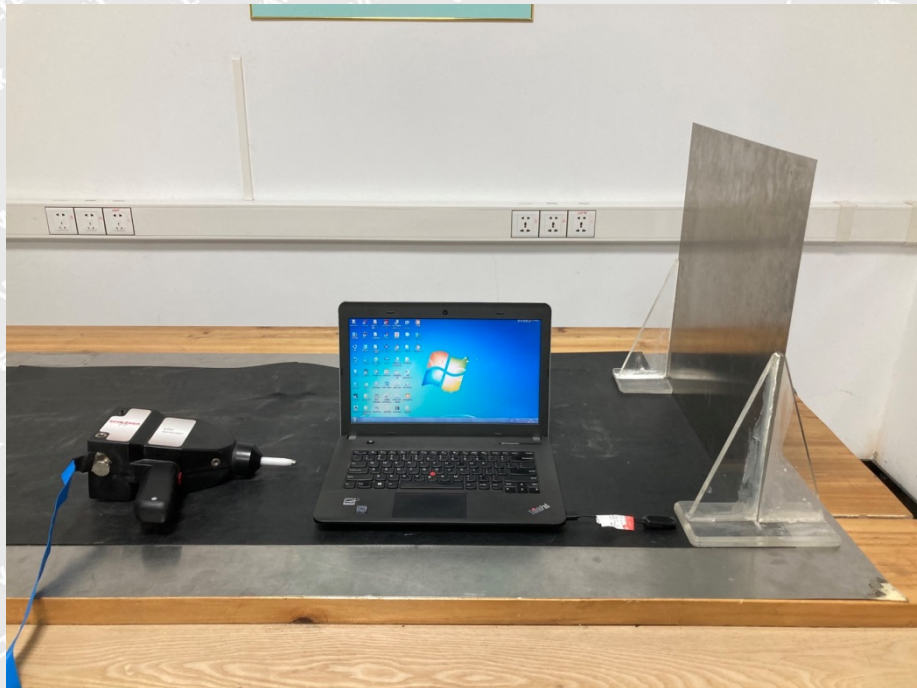

8.4 Photograph – Radio-frequency electromagnetic fields Test Setup

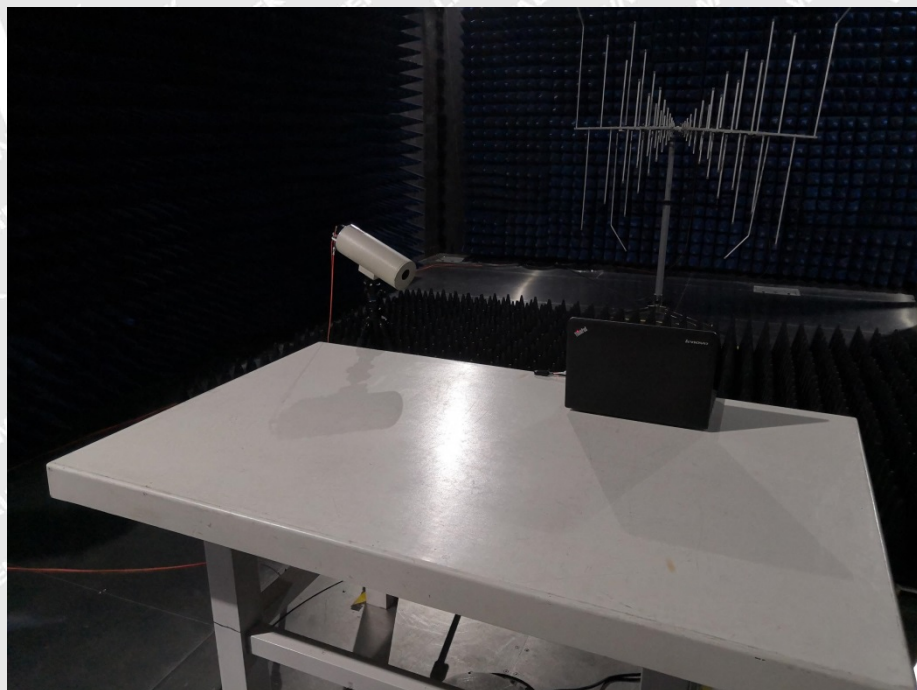



9 Photographs–Constructional Details

9.1 EUT– AppearanceView

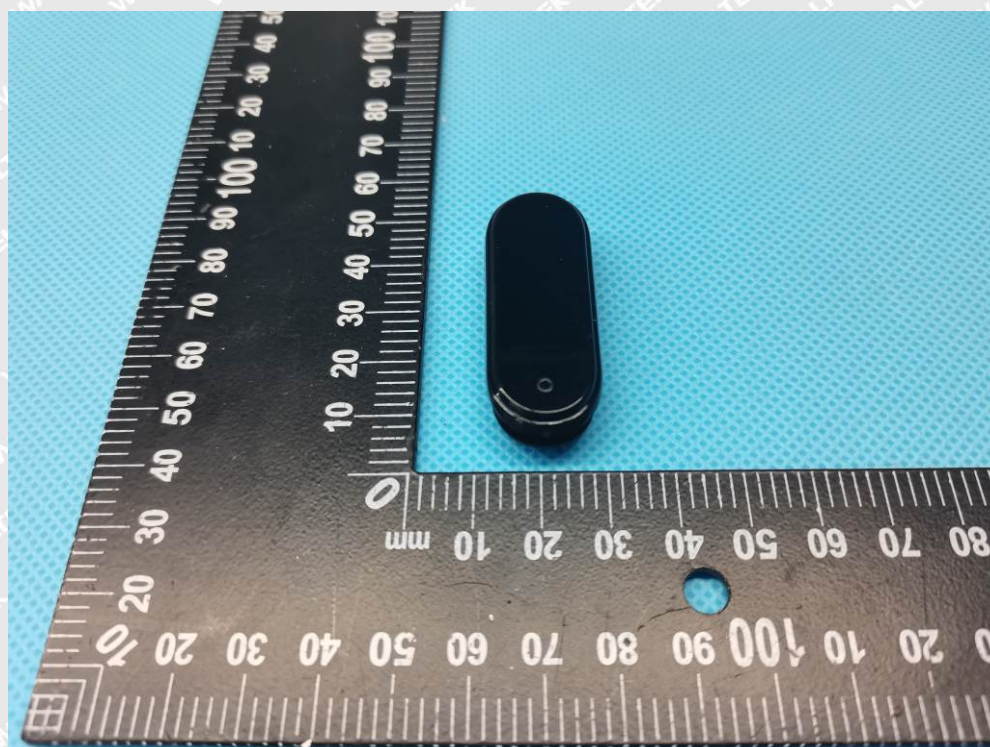
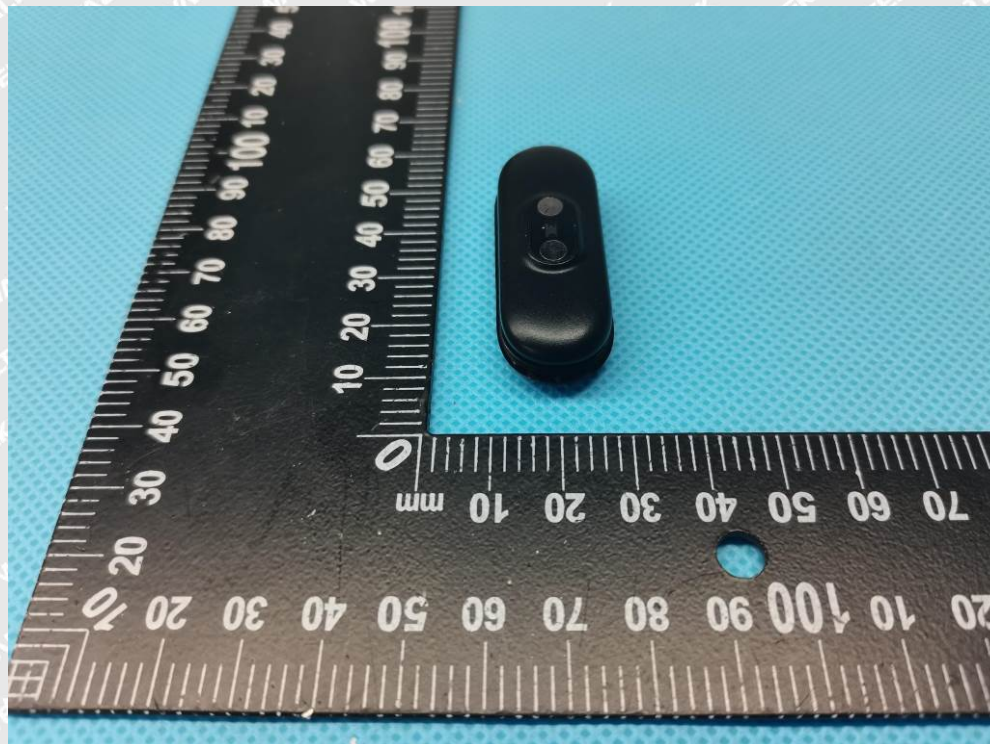

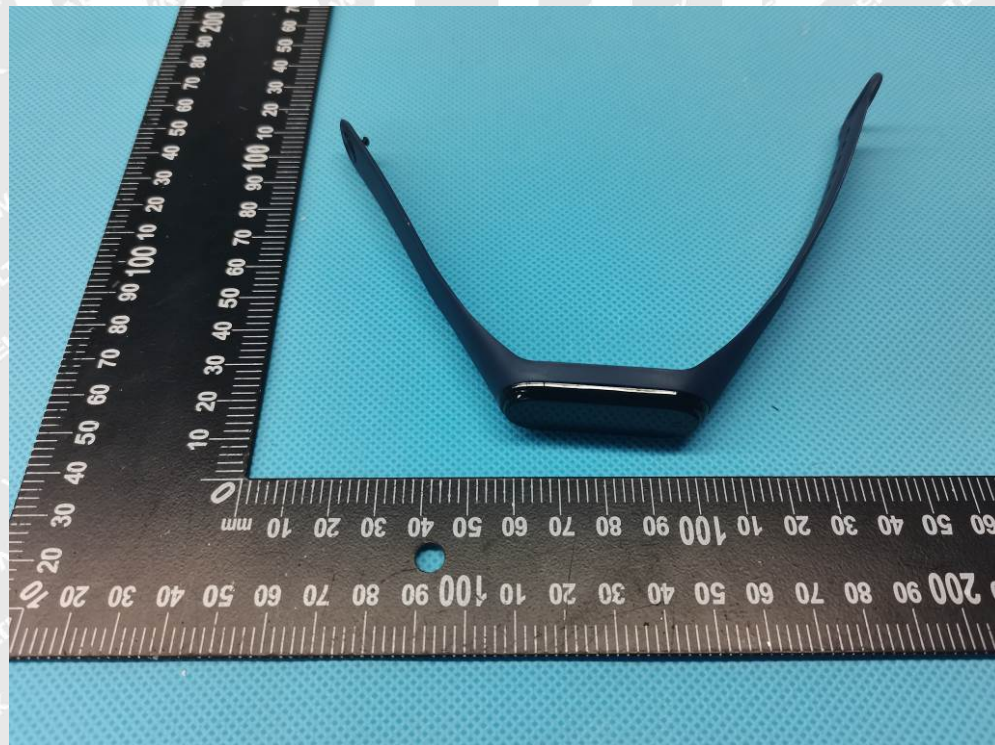
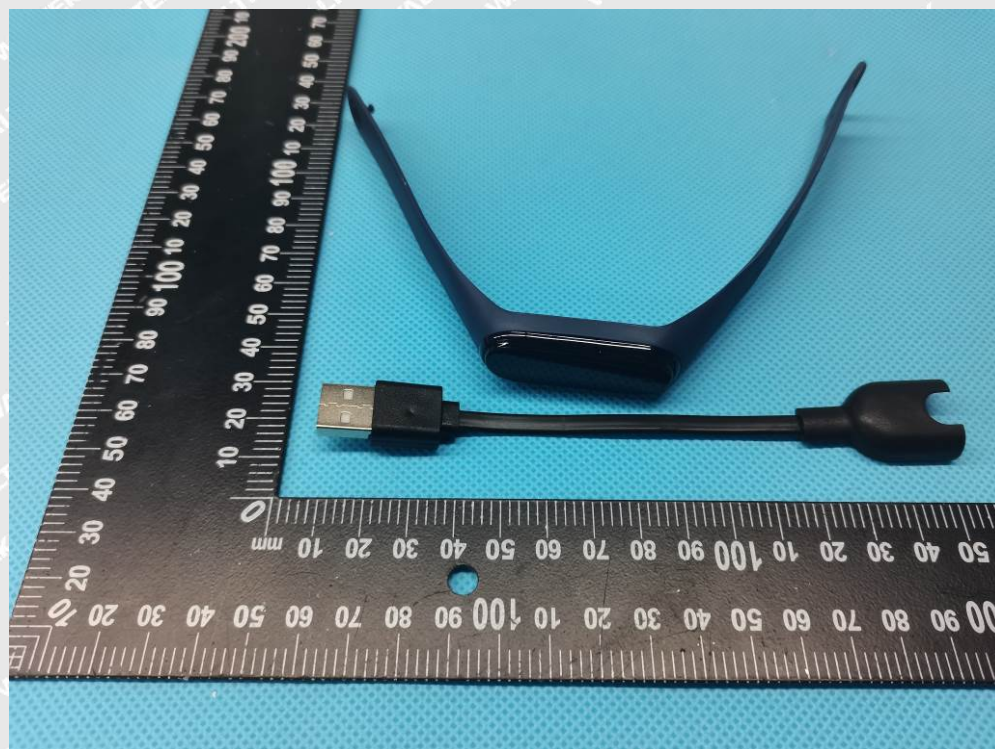

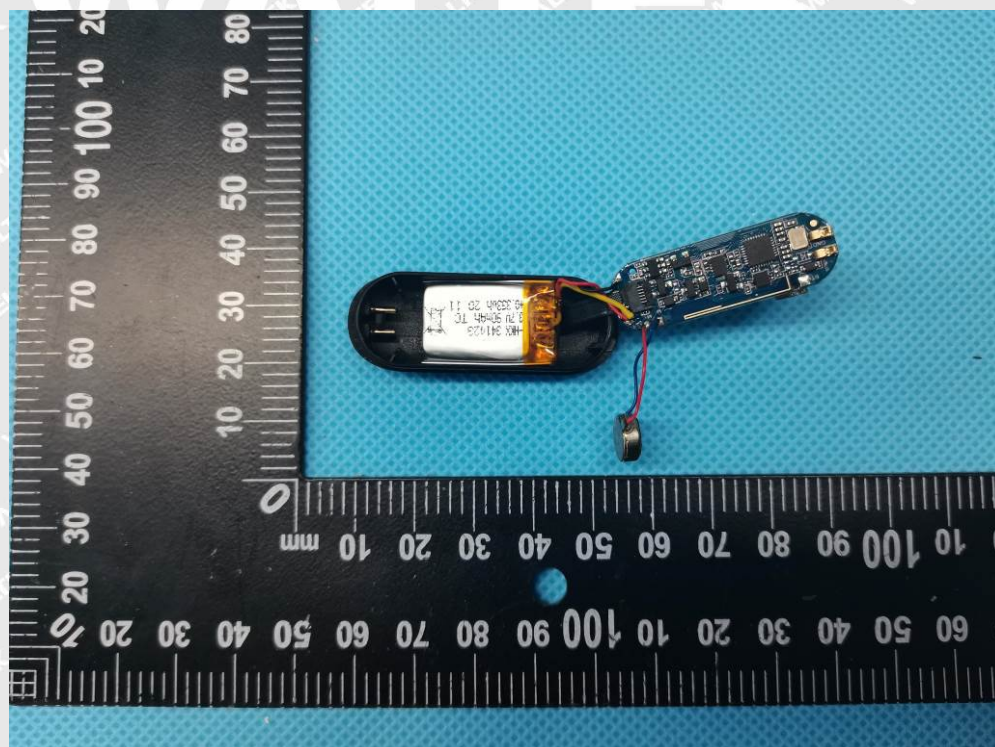

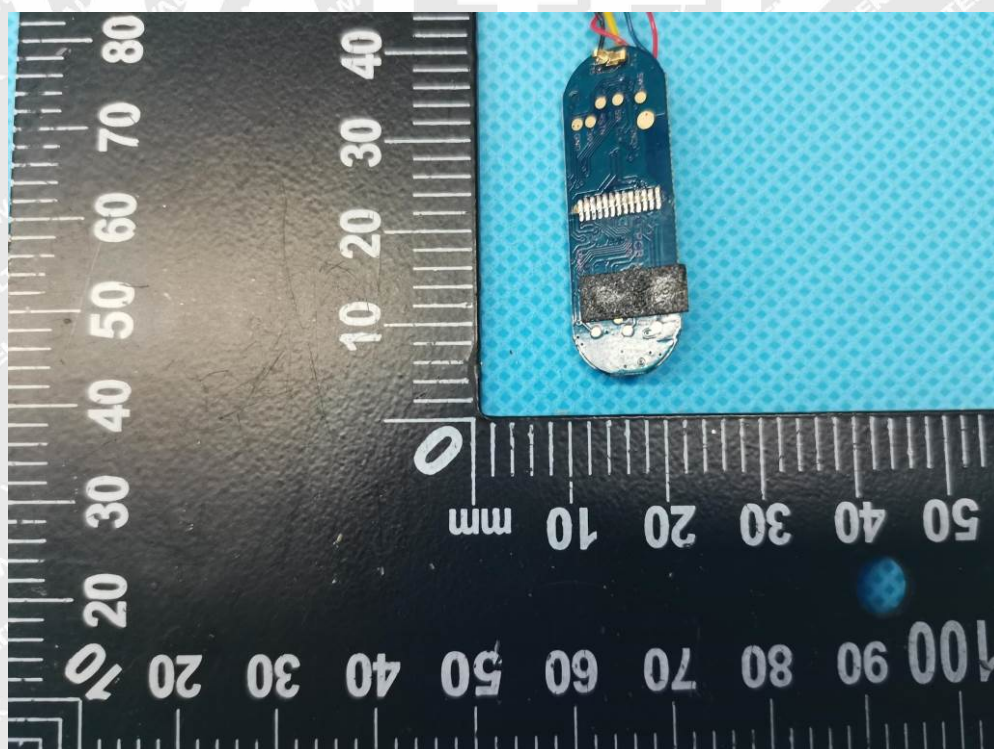

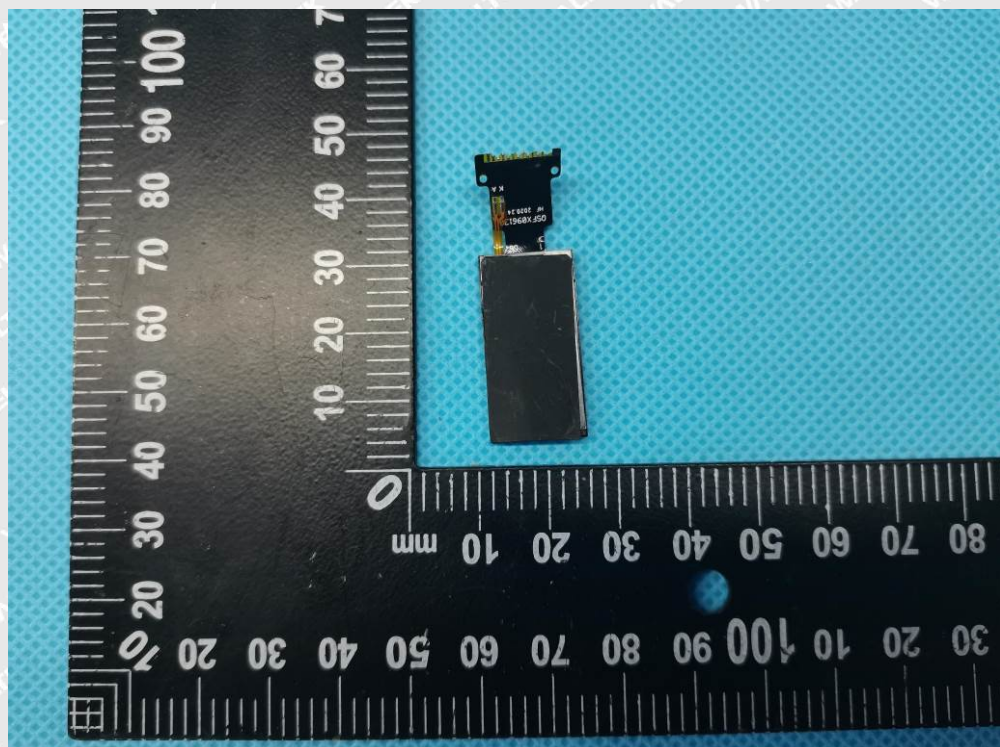
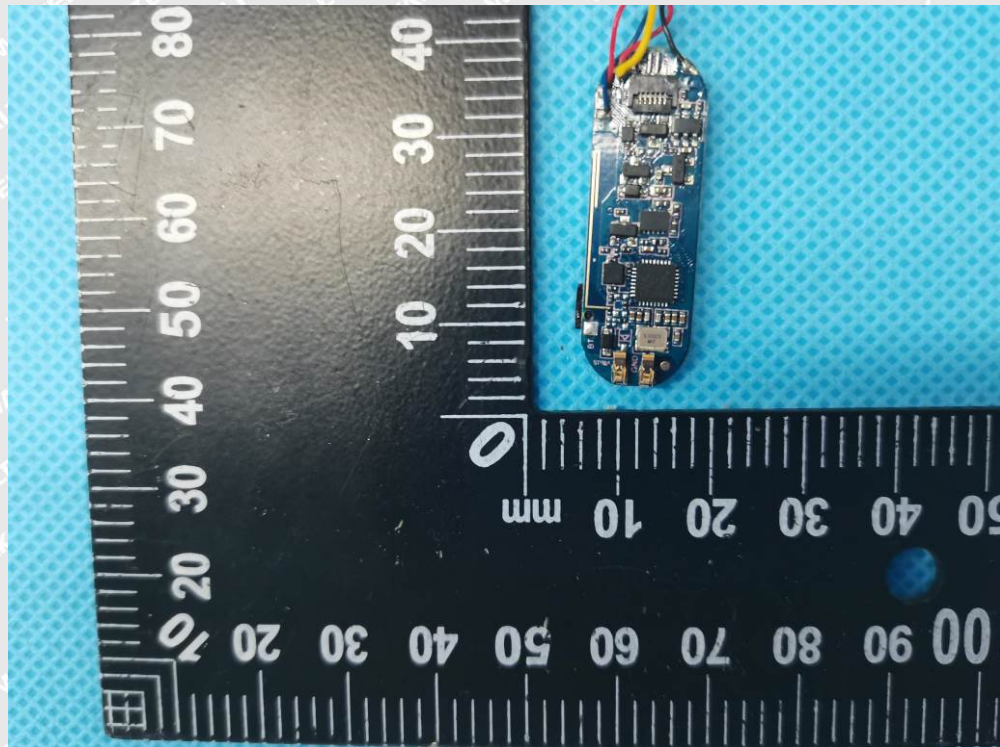

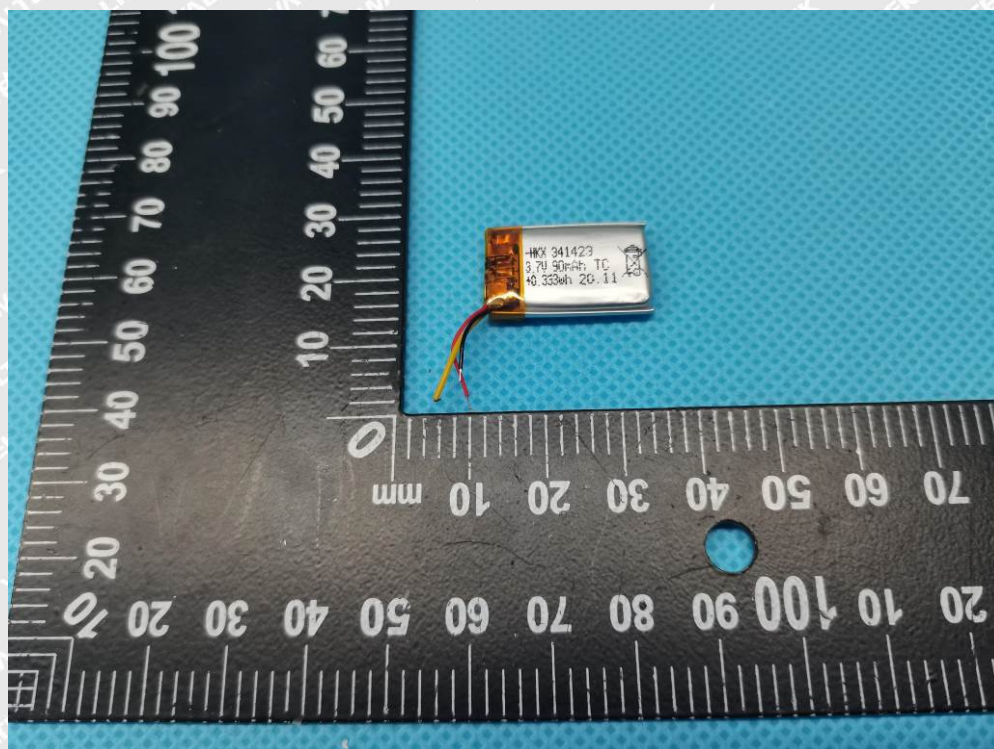
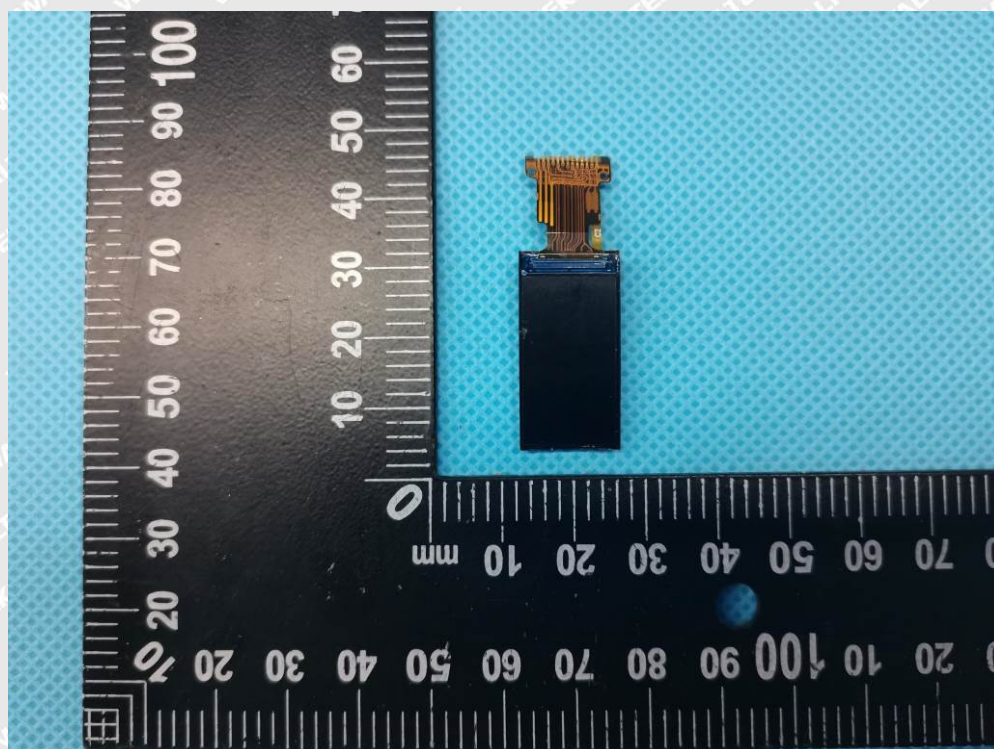



====End of Report====

WALTEK